



*An Online PDH Course
brought to you by
CEDengineering.com*

Power Transformer Protection

Course No: E06-003

Credit: 6 PDH

Velimir Lackovic, Char. Eng.



Continuing Education and Development, Inc.

P: (877) 322-5800
info@cedengineering.com

www.cedengineering.com

The advancement of electrical power systems has been reflected in the developments in power transformer manufacturing. This has led to a wide range of power transformers. Their ratings range from a few kVA to several hundred MVA and are used for a wide variety of applications. Power transformer protection varies with the application and transformer importance. In the case of a fault within the power transformer it is important to minimize tripping time in order to decrease the impact of thermal stress and electrodynamic forces. Distribution power transformers can be protected by using fuses or overcurrent protection relays. This leads to time-delayed protection due to downstream co-ordination requirements. Nevertheless, time delayed short circuit clearance is unacceptable on larger power transformers due to system operation/stability and cost of repair.

Power transformer short circuits are typically grouped into five categories:

- Winding and terminal short circuits
- Core short circuits
- Tank and transformer accessory short circuits
- On-load tap changer short circuits
- Prolonged or uncleared external short circuits

Summary of short circuit causes initiated in the power transformer itself, is shown in Figure 1.

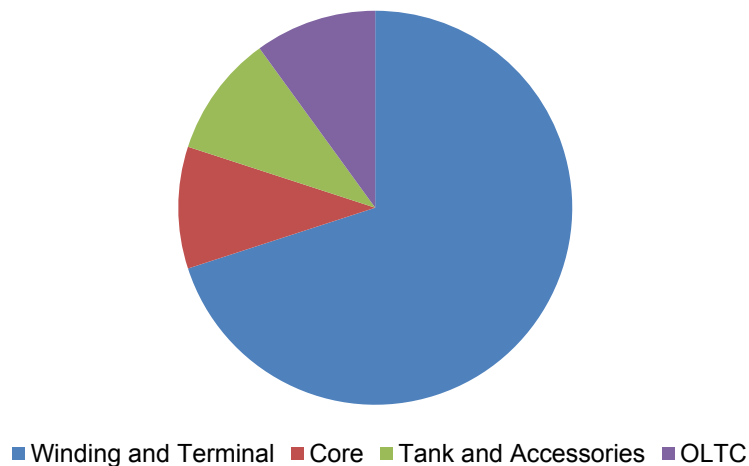

Figure 1. Power transformer short circuit statistics

TRANSFORMER WINDING FAULTS

A transformer winding fault is limited in magnitude by the following factors:

- source impedance
- neutral grounding impedance
- winding connection arrangement
- fault voltage
- power transformer leakage reactance

Few distinct cases come up and are described below.

STAR-CONNECTED TRANSFORMER WINDING WITH NEUTRAL POINT GROUNDED THROUGH AN IMPEDANCE

The winding ground fault current depends on the grounding impedance value and is also directly proportional to the distance of the fault from the transformer neutral point, since the fault voltage will be directly proportional to this distance. For a fault on a transformer secondary winding, the matching primary current will depend on the transformation ratio between the primary winding and the short-circuited secondary turns. This also changes with fault position, so that the fault current in the transformer primary winding is directly proportional to the square of the fraction of the winding that is short-circuited. The case is presented in Figure 2. Faults in the lower third of the transformer winding generate very little current in the primary winding and that makes fault detection by primary current measurement challenging.

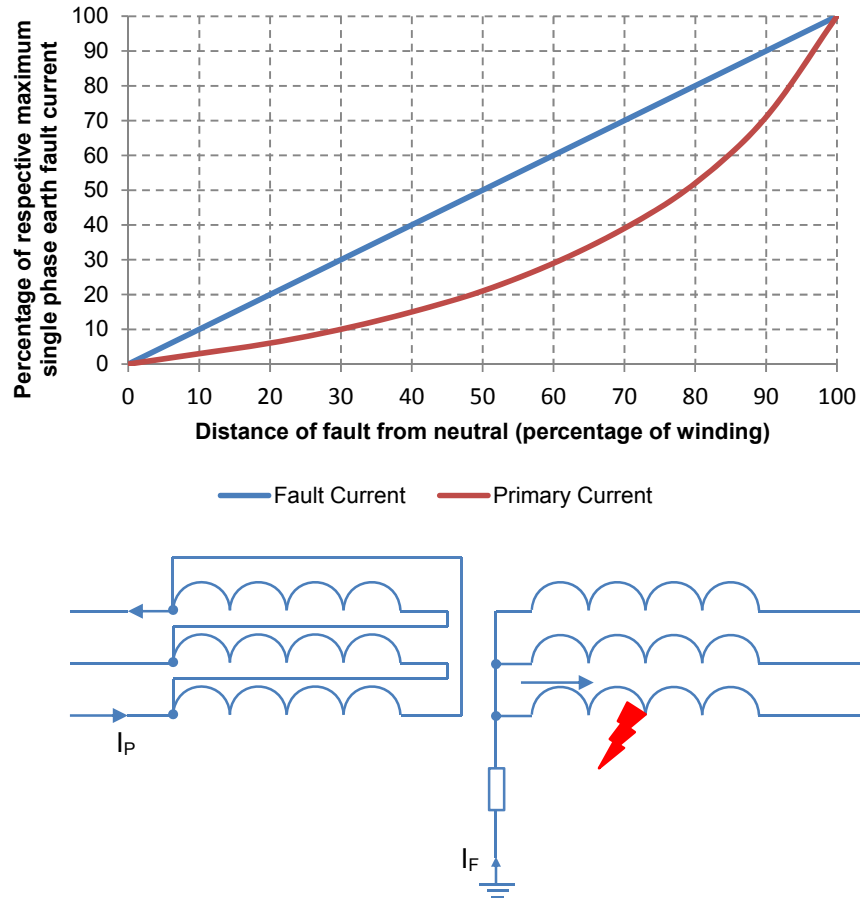

Figure 2. Ground fault current in resistance grounded star winding

STAR-CONNECTED WINDING WITH NEUTRAL POINT SOLIDLY GROUNDED

The fault current is limited by the leakage reactance of the transformer winding, which changes in a complex pattern with the fault position. The variable fault point voltage is also a critical factor, as in the case of impedance grounding. For faults close to the neutral end of the transformer winding, the reactance is very low, and results in the greatest fault currents. The variation of current with fault location is presented in Figure 3.

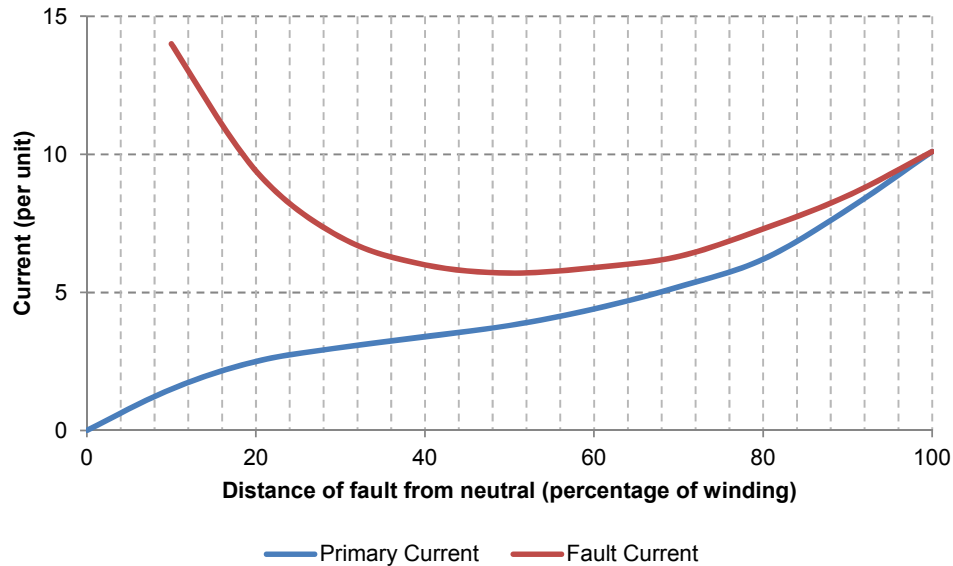

Figure 3. Ground fault current in solidly grounded star winding

For transformer secondary winding faults, the primary winding fault current is found by the variable transformation ratio. Since the secondary fault current magnitude remains high throughout the winding, the primary fault current is significant for most points along the transformer winding.

DELTA-CONNECTED TRANSFORMER WINDING

Delta-connected winding elements do not operate with a voltage to earth of less than 50% of the phase voltage. Hence, the range of fault current magnitude is less than for a star winding. The real figure of fault current will still depend on the system grounding. It has to be noted that the impedance of a transformer delta winding is especially high to fault currents running to a centrally placed fault on one leg. It can be expected that the impedance is between 25% and 50%, depending on the power transformer rating, regardless of the normal balanced through-current impedance. Since the prefault voltage to ground at this point is half the normal phase voltage, the ground fault current may be no more than the rated current, or even less than this figure if the source or system grounding impedance is appreciable. The current will run to the fault location from each side through the two half windings, and will be split between two phases of the system. Hence, the individual phase currents may be relatively low which can cause difficulties in providing protection.

PHASE TO PHASE TRANSFORMER FAULTS

Faults between phases within a transformer are relatively uncommon. However, in the case such fault happens, it will give rise to a significant current comparable to the ground fault currents.

INTERTURN TRANSFORMER FAULTS

In low voltage transformers, interturn insulation breakdown is unlikely to happen unless the mechanical force on the winding due to external short circuits has caused insulation degradation, or insulating oil (if used) has become contaminated by moisture. A high voltage power transformer connected to an overhead transmission line will be exposed to steep fronted impulse voltages, developing from lightning strikes, network faults and switching processes. A line surge, which may be of few times the nominal system voltage, will concentrate on the transformer winding end turns because of the high equivalent frequency of the surge front. Part-winding resonance, involving voltages up to 20 times nominal voltage, may happen. The interturn insulation of the winding end turns is strengthened, but cannot be enhanced in proportion to the insulation to ground, which is relatively high. Therefore, partial winding flashover is more likely. The consequent progress of the fault, if not discovered in the earliest stage, may well destruct the evidence of the real cause.

A short circuit of a few turns of the transformer winding will give rise to a big fault current in the short-circuited loop. However, the terminal currents will be very small, because of the high ratio of transformation between the whole winding and the short circuited turns.

The graph in Figure 4 presents the relevant information for a typical transformer of 3.25% impedance with the short circuited turns symmetrically placed in the winding center.

TRANSFORMER CORE FAULTS

A conducting bridge across the laminated structures of the transformer core can allow sufficient eddy-currents which can cause serious overheating. The bolts that clamp the core together are always insulated to prevent this problem. If any part of the core

insulation becomes faulty, the resultant heating may attain a magnitude sufficient to damage the winding.

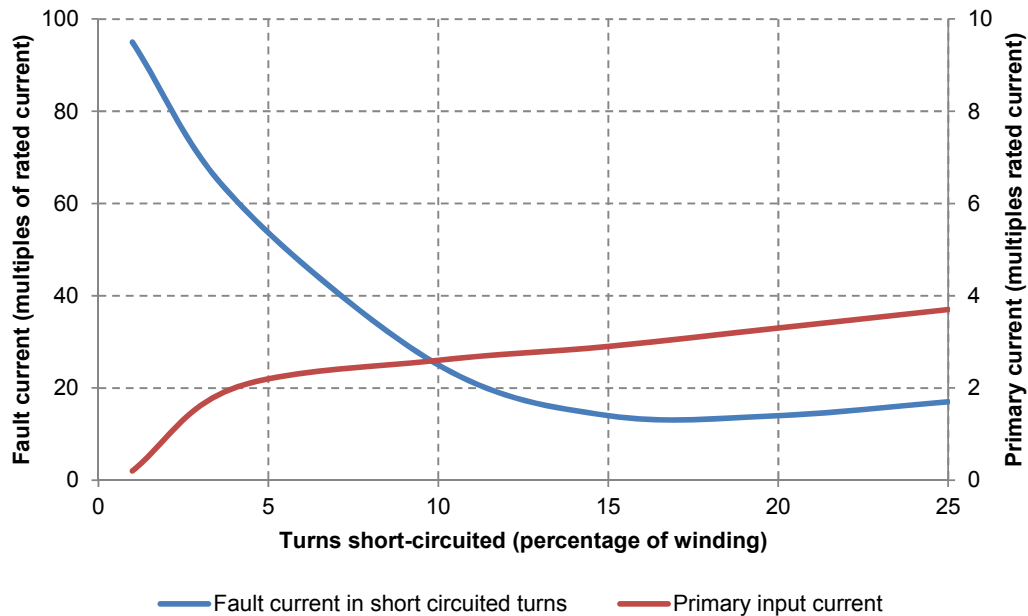

Figure 4. Interturn fault current/number of short-circuited turns

Even though additional core loss causes serious local heating, it does not generate a detectable change in input current and could not be discovered by the typical electrical protection. Nevertheless it is crucial that the situation is discovered before a significant fault has been created. In an oil-immersed power transformer, core heating high enough to cause winding insulation damage also causes oil breakdown with an accompanying evolution of gas. This gas flows to the conservator and is used to run a mechanical relay.

TRANSFORMER TANK FAULTS

Loss of oil through transformer tank leaks eventually creates a dangerous situation, either because of a reduction in winding insulation or because of. Overheating may also happen due to sustained overload, blocked cooling ducts or failure of the forced cooling mechanism.

EXTERNALLY APPLIED CONSIDERATIONS

Causes of abnormal stress in a power transformer are:

- overload
- system short circuits
- overvoltage
- reduced system frequency

OVERLOAD

Overload creates increased 'copper loss' and a subsequent temperature increase. Overloads can be tolerated for limited periods and suggestions for oil-immersed power transformers are provided in IEC 60354.

The transformer thermal time constant of naturally cooled power transformers lies between 2.5-5 hours. Shorter time constants are applicable for the force-cooled power transformers.

SYSTEM SHORT CIRCUITS

System faults generate a relatively intense heating rate of the feeding transformers while the copper loss increases in proportion to the square of the per unit short circuit current. The common external short circuits duration that power transformer can sustain without damage if the fault current is limited only by the self-reactance is presented in Table 1. IEC 60076 gives additional instructions on short-circuit withstand levels.

Transformer reactance (%)	Short circuit current (Multiple of rating)	Allowable fault duration (seconds)
4	25	2
5	20	2
6	16.6	2
7	14.2	2

Table 1. Power transformer short circuit current withstand information

Maximum mechanical stress on transformer windings happens during the first cycle of the fault. Avoidance of damage is a matter of power transformer design.

OVERVOLTAGES

Overvoltage situations are of two kinds:

- transient surge voltages
- power frequency overvoltage

Transient overvoltages develop from faults, switching, and lightning disturbances. They are liable to cause interturn faults. These overvoltages are typically fixed by shunting the high voltage terminals to ground either with a plain rod gap or by surge diverters, which constitute a stack of short gaps in series with a non-linear resistor. The surge diverter, in contrast to the rod gap, has the advantage of eliminating the flow of power current after discharging a surge. In this way it prevents subsequent transformer isolation.

Power frequency overvoltage causes both an increase in insulation stress and a proportionate working flux increase. The second effect increases both the iron loss and magnetising current. In addition, flux is diverted from the laminated core into structural steel elements. The core bolts, which typically carry little flux, may be exposed to a high flux diverted from the greatly saturated region of core alongside. This ends in a rapid temperature rise in the bolts, damaging their and coil insulation.

REDUCED SYSTEM FREQUENCY

System frequency reduction affects flux density. Transformer can function with some degree of overvoltage with a matching increase in frequency, but transformer service must not be extended with a high voltage input at a low frequency. Service cannot be maintained when the ratio of voltage to frequency, with these quantities expressed in per unit of their rated values, exceeds unity by more than a small number, for example if $V/f > 1.1$. If a significant increase in system voltage has been taken care of in the transformer design stage, the base of 'unit voltage' should be taken as the greatest voltage for which the power transformer is designed.

TRANSFORMER MAGNETISING INRUSH

The process of magnetizing inrush is a transient condition that primarily happens when a power transformer is energized. It is not a fault condition, and hence transformer

protection must stay stable during the inrush transient. Figure 5(a) presents a power transformer magnetizing characteristic. To minimize costs, weight and size, power transformers are typically operated near to the 'knee point' of the magnetizing curve. Accordingly, only a small raise in core flux above normal working levels will end in a great magnetizing current. Under normal steady-state conditions, the magnetizing current related with the operating flux level is relatively small, as presented in Figure 5(b). Nevertheless, if a power transformer winding is energized at a voltage zero, with no remnant flux, the flux level during the first voltage cycle (2 x normal flux) will end in core saturation and a great non-sinusoidal magnetizing current waveform, as presented in Figure 5(c). This current is known as magnetizing inrush current and may remain for few cycles. Few factors impact the magnitude and magnetizing current inrush duration:

- point on wave switching
- residual flux – worst-case conditions end in the flux peak value achieving 280% of normal value
- number of banked power transformers
- transformer design and rating
- system short circuit current level

The big flux densities mentioned above are so far beyond the normal working range that the incremental relative permeability of the core approximates to unity and the inductance of the transformer winding falls to a figure near that of the 'aircored' inductance. The current wave, starting from zero, increases slowly at first. The flux has a value just above the residual value and the permeability of the core being fairly big. As the flux passes the normal working value and enters the greatly saturated portion of the magnetizing curve, the inductance decreases and the current quickly rises to a peak that may be 500% of the steady state magnetizing current.

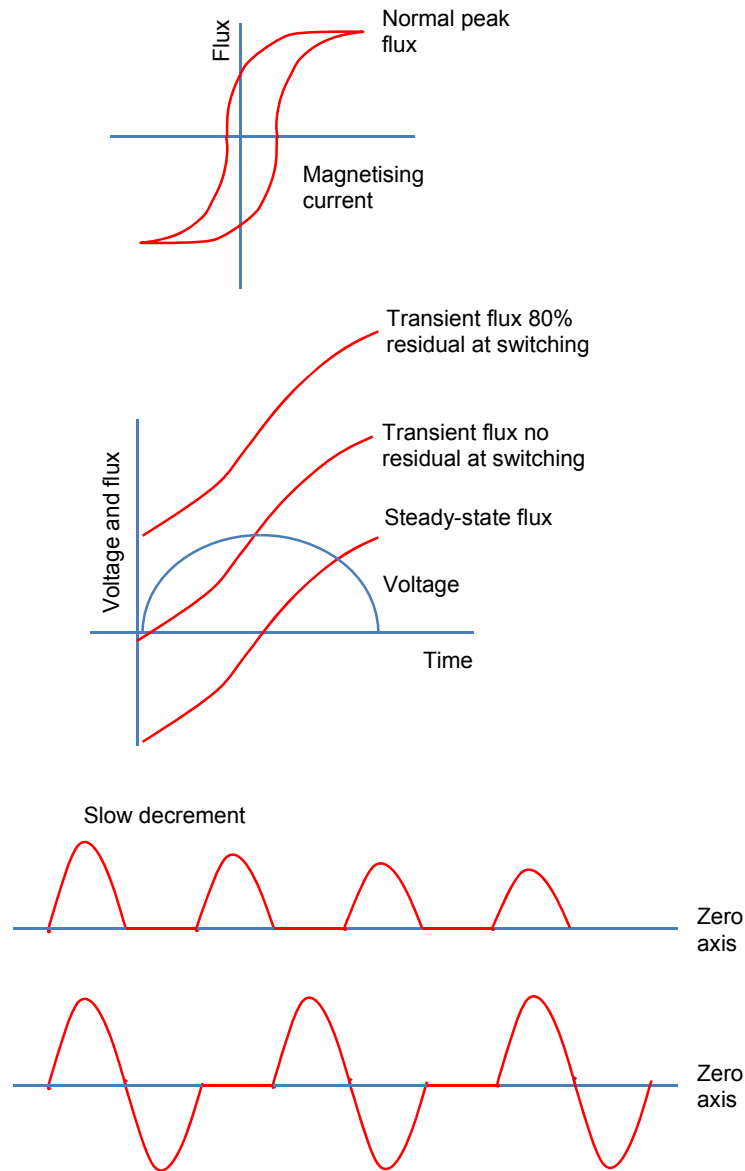

Figure 5. Power transformer magnetizing inrush (a) Common magnetizing characteristic (b) Steady and maximum offset fluxes (c) Common inrush current (d) Inrush without offset, due to yoke saturation

When the peak is passed at the next voltage zero, the next negative half cycle of the voltage wave decreases the flux to the starting value and the current symmetrically drops to zero. Hence, the current wave is totally offset and is only restored to the steady state condition by the circuit losses. The transient time constant has a range between 0.1 second (for a 100kVA power transformer) to 1.0 second (for a large power transformer). As the magnetizing characteristic is non-linear, the envelope of the

transient current is not purely of exponential form. It can be noted that the magnetizing current changes up to 30 minutes after switching on. Even though right choice of the point on the wave for a single– phase power transformer will result in no transient inrush, mutual effects ensure that a transient inrush happens in all phases for three-phase power transformers.

INRUSH WAVEFORM HARMONIC CONTENT

The power transformer magnetizing current waveform contains a proportion of harmonics that increments as the peak flux density is raised to the saturating condition. The transformer magnetizing current contains a third harmonic and increasingly smaller amounts of fifth and higher harmonics. If the saturation degree is progressively increased, not only will the harmonic content increment as a whole, but the relative proportion of fifth harmonic will increase and finally outmatch the third harmonic. At a higher level the seventh would overcome the fifth harmonic but this needs a degree of saturation that will not be experienced with power transformers.

The energizing conditions that end in an offset inrush current create a waveform that is asymmetrical. Such a wave commonly comprises both even and odd harmonics. Common inrush currents contain significant amounts of second and third harmonics and diminishing amounts of higher orders. As with the steady state wave, the proportion of harmonics changes with the saturation degree, so that as a dangerous inrush transient decays, the harmonic makeup of the current goes through a range of conditions.

POWER TRANSFORMER OVERHEATING

The power transformer rating is based on the temperature increase above an assumed maximum ambient temperature. Sustained overload is not typically allowable under this condition. Certain degree of sustained overload can be tolerated at a lower ambient temperature. Short-term overloads are also allowable to an extent dependent on the previous loading conditions. IEC 60354 standard gives assistance in this respect. The only true statement is that the transformer winding must not overheat. Temperature of about 95°C is conceived as the normal maximum working value beyond which an additional increase of 8°- 10°C, if maintained, will halve the

transformer insulation life. Hence, overload protection is based on winding temperature, which is typically measured by a thermal image technique. Protection is set to trip the power transformer if excessive temperature is achieved. The trip signal is typically routed via a digital input of a protection relay on one side of the power transformer, with both alarm and trip facilities made available through programmable logic in the protection relay. Intertripping between protection relays on the two sides of the power transformer is typically used to ensure total disconnection of the transformer. Winding temperature protection may be part of a overall monitoring package.

OVERVIEW OF THE POWER TRANSFORMER PROTECTION

The issues relating to power transformers presented in previous sections require some means of protection. Table 2 presents the problems and the potential protection forms that may be applied. The next sections give more details on the individual protection methods. It is typical for a modern protection relay to provide all of the needed protection functions in a single package. Electromechanical technology would involve several protection relays with interconnections and higher overall CT burdens.

Fault type	Protection used
Secondary winding phase-ground fault	Differential, Restricted ground fault
Interturn fault	Differential, Buchholz
Core fault	Differential, Buchholz
Tank fault	Differential, Buchholz, Tank-ground
Overheating	Thermal
Primary winding phase-phase fault	Differential, Overcurrent
Primary winding phase-ground fault	Differential, Overcurrent
Secondary winding phase-phase fault	Differential
Overfluxing	Overfluxing

Table 2. Power transformer fault types/protection arrangements

TRANSFORMER OVERCURRENT PROTECTION

Fuses may adequately protect small power transformers, but larger ones need overcurrent protection using a protection relay and circuit breaker, as fuses do not have the needed fault breaking capacity.

FUSES

Fuses typically protect small distribution transformers up to ratings of 1MVA at distribution voltages. In many situations no circuit breaker is provided, making fuse protection the only available way of automatic isolation. The fuse must have a rating well above the maximum power transformer load current to resist the short duration overloads that may happen. Also, the fuses must resist the magnetizing inrush currents taken when power transformers are energized. High Rupturing Capacity (HRC) fuses, even though very fast in operation with huge fault currents, are super slow with currents of less than three times their nominal value. Such fuses will do little to protect the power transformer, serving only to protect the system by disconnecting a faulty power transformer after the fault has reached an advanced stage. Table 3 presents common ratings of fuses for use with 11kV power transformers.

Transformer Rating		Fuse	
kVA	Full load current (A)	Nominal current (A)	Operating time at 3 x Rating (s)
100	5.25	16	3.0
200	10.5	25	3.0
315	15.8	36	10.0
500	26.2	50	20.0
1000	52.5	90	30.0

Table 3. Common fuse ratings for application with distribution transformers

Above table should be taken only as a common example. Significant differences exist in the time curves of different types of HRC fuses. Moreover, grading with secondary side protection has not been looked at.

OVERCURRENT PROTECTION RELAYS

With the arrival of ring main units comprising SF6 circuit breakers and isolators, protection of distribution transformers can now be achieved by overcurrent trips or by protection relays connected to current transformers connected on the transformer primary side. Overcurrent protection relays are also used on bigger transformers equipped with standard circuit breaker control. Improvement in relay protection is achieved in two ways; the great delays of the HRC fuse for lower fault currents are

averted and ground-fault tripping element is provided in addition to the overcurrent element. The time delay curve should be selected to discriminate with circuit protection on the transformer secondary side. A high-set instantaneous protection relay element is typically provided, the current setting being selected to avoid operation for a secondary short circuit. This allows high-speed clearance of primary terminal short circuits.

RESTRICTED EARTH FAULT PROTECTION

Conventional ground fault protection using overcurrent devices fails to give proper protection for power transformer windings. This is especially true for a star-connected winding with an impedance-grounded neutral. The protection degree is considerably improved by the usage of restricted earth fault protection (or REF protection). This is a unit protection arrangement for one winding of the transformer. It can be a high impedance type as presented in Figure 6 or a biased low-impedance type. For the high impedance arrangement, the residual current of three line current transformers is balanced against the output of a current transformer in the neutral conductor. In the biased low impedance arrangement, the three line currents and the neutral current become the bias inputs to a differential device. The system is functional for faults within the region between current transformers, that is, for faults on the star winding. The system stays stable for all faults outside this protection zone.

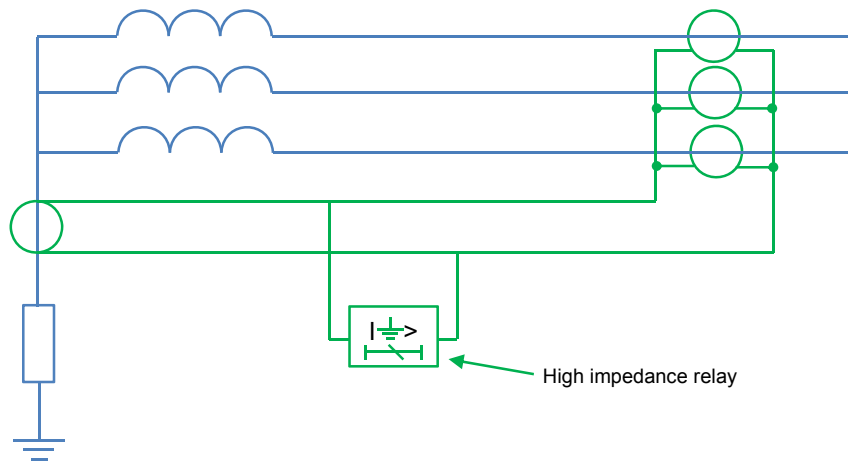

Figure 6. Star winding restricted earth fault protection

Improvement in protection performance comes not only from using an instantaneous protection relay with a low setting, but also because the total short circuit current is measured, not only the transformed component in the transformer HV primary winding (if the star winding is a secondary winding). Restricted earth fault protection is usually used even when the neutral is solidly grounded. Since short circuit current then stays at a high value even to the last turn of the transformer winding, nearly complete cover for ground faults is achieved. This is an improvement in comparison with the performance of systems that do not measure the neutral conductor current.

Ground fault protection use for delta-connected or ungrounded star winding is inherently restricted, since no zero sequence components can be transferred through the transformer to the other windings. Both transformer windings can be separately protected with restricted earth fault protection. This arrangement provides high speed protection against ground faults for the complete transformer with relatively simple equipment. A high impedance relay is applied, allowing fast operation and phase fault stability.

TRANSFORMER DIFFERENTIAL PROTECTION

The restricted earth fault arrangement completely depends on the Kirchhoff principle that the sum of the currents running into a conducting network is zero. A differential system can be organized to protect the complete transformer. This is possible due to transformer high efficiency operation, and the similar equivalence of ampere turns generated on the primary and secondary windings. Figure 7 presents the principle. Current transformers on the primary and secondary sides are connected to form a circulating current system.

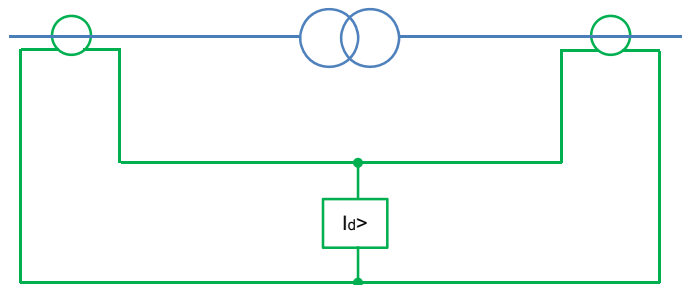

Figure 7. Transformer differential protection principle

TRANSFORMER DIFFERENTIAL PROTECTION BASIC CONSIDERATIONS

A variety of considerations have to be kept in mind when applying the principles of differential protection to power transformers. These considerations include:

- the possible occurrence of overfluxing
- the impacts of the variety of grounding and winding arrangements (filtering of zero sequence currents)
- correction for potential phase shift across the transformer windings (phase correction)
- the impact of magnetizing inrush during initial start
- correction for potential unbalance of signals from current transformers on either side of the transformer windings (ratio correction)

In traditional transformer differential arrangements, the demands for phase and ratio correction were met by the application of external interposing current transformers (ICTs) or by a delta connection of the main CTs to give phase correction. Digital/numerical protection relays use ratio and phase correction. It is implemented through the software and enables most combinations of transformer winding schemes, irrespective of the winding connections of the primary CTs. It does not need the additional space and cost requirements of hardware interposing CTs.

LINE CURRENT TRANSFORMER PRIMARY RATINGS

Line current transformers have primary ratings chosen to be about same as nominal currents of the transformer windings to which they are applied. Primary ratings will typically be fixed to those of available standard ratio CTs.

PHASE CORRECTION

Transformer differential protection correct operation requires that the power transformer primary and secondary currents, as measured by the protection relay, are in phase. If the power transformer is delta/star connected, balanced three phase through current is phase shifted for 30° , as presented in Figure 8. If left uncorrected, this phase difference would lead to the protection relay seeing through current as an

unbalanced fault current, and result in relay operation. Phase correction must be applied.

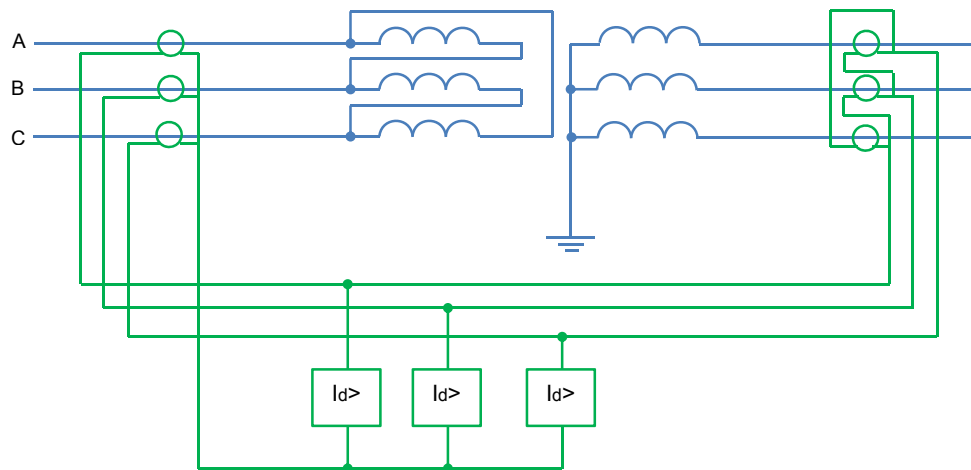

Figure 8. Differential protection for two-winding delta/star power transformer

Electromechanical and static protection relays use adequate CT/ICT connections to assure that the primary and secondary currents transferred to the protection relay are in phase. For digital and numerical protection relays, it is typical to use star connected line CTs on all transformer windings and compensate for the winding phase shift using software. Depending on protection relay design, the only information needed in such circumstances may be the transformer vector group. Phase compensation is then automatically completed. Caution is needed if such protection relay is used to replace an existing electromechanical or static relay since the primary and secondary line CTs may not have the same winding arrangement. In such situations, phase compensation and related protection relay data entry needs more detailed consideration. Occasionally, the available phase compensation facilities cannot accommodate the power transformer winding connection. Interposing CTs must be used in such situations.

ZERO SEQUENCE CURRENT FILTERING

It is important to provide some method of zero sequence filtering when a transformer winding can pass zero sequence current to an external ground fault. This is to ensure that out-of-zone ground faults are not detected by the power transformer protection as an in-zone fault. This is accomplished by use of delta-connected line CTs or

interposing CTs for older protection relays. The winding connection of the line and/or interposing CTs must take this into consideration, in addition to any necessary phase compensation. For digital/numerical protection relays, the required filtering is provided in the protection relay software. Table 4 presents the phase compensation and zero sequence filtering requirements.

Transformer Connection		Transformer Phase Shift	Clock face vector	Phase compensation needed	HV Zero Sequence Filtering	LV Zero Sequence Filtering
Yy0		0°	0°	0°	Yes	Yes
Zd0					Yes	
Dz0						Yes
Dd0						
Yz1	Zy1	30°	1	30°	Yes	Yes
Yd1					Yes	
Dy1						Yes
Yy6		180°	1	180°	Yes	Yes
Zd6					Yes	
Dz6						Yes
Dd6						
Yz11	Zy11	30°	11	30°	Yes	Yes
Yd11					Yes	
Dy11						Yes
YyH	YzH	(H/12)x360°	Hour 'H'	-(H/12)x360°	Yes	Yes
YdH	ZdH				Yes	
DzH	DyH					Yes
DdH						

Table 4. Current transformer connection for power transformers of different vector groups

RATIO CORRECTION

Correct service of the differential element demands that currents in the differential element balance under load and through fault conditions. As the primary and secondary line CT ratios may not precisely match the power transformer rated winding currents, digital/numerical protection relays are provided with ratio correction factors for each of the CT inputs. The correction factors may be automatically computed by the protection relay from knowledge of the line CT ratios and the transformer MVA rating. Nevertheless, if interposing CTs are applied, ratio correction may not be simple task and may need to consider a factor of $\sqrt{3}$ if delta-connected CTs or ICTs are

involved. If the power transformer is equipped with a tap changer, line CT ratios and correction factors are typically selected to reach current balance at the mid tap of the power transformer. It is mandatory to ensure that current mismatch due to off-nominal tap service will not cause spurious operation.

BIAS SETTING

Bias is used for transformer differential protection for the same reasons as any unit protection arrangement – to give stability for external faults while allowing sensitive settings to pick up internal faults. The situation is more complex if a tap changer is present. With line CT/ICT ratios and correction factors set to reach current balance at nominal tap, an off-nominal tap may be perceived by the differential protection as an internal fault. By choosing the minimum bias to be higher than sum of the maximum tap of the power transformer and possible CT errors, malfunctioning due to this cause is averted. Some protection relays use a bias characteristic with three parts, as presented in Figure 9. The first part is set higher than the transformer magnetizing current. The second part is set to allow for off-nominal tap settings, while the third part has bigger bias slope beginning well above nominal current to cater for heavy through-fault situations.

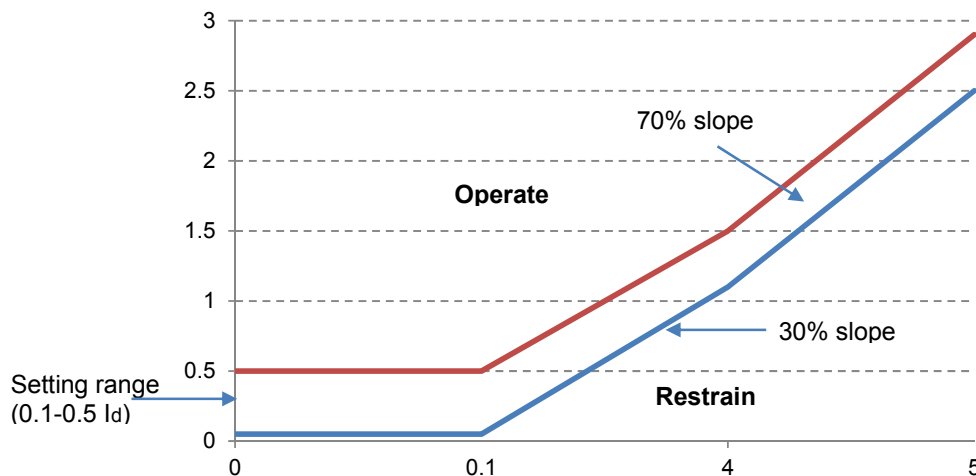

Figure 9. Typical bias function

POWER TRANSFORMERS WITH MULTIPLE WINDINGS

The unit protection principle stays valid for a system having more than two connections, so a power transformer with three or more windings can still be protected by using above principles. When the power transformer has only one of its three

windings connected to a source of supply, with the other two windings supplying loads, a protection relay with only two sets of CT inputs can be applied. It is connected as presented in Figure 10(a). The different load currents are added in the CT secondary circuits, and they balance with the infeed current on the supply side. In the case there is more than one source of fault current, there is a danger in the arrangement presented in Figure 10(a). In that case there is a danger of current circulating between the two paralleled sets of current transformers without generating any bias. Hence, it is important a protection relay is used with separate CT inputs for the two secondary sides as shown in Figure 10(b). In the case third winding consists of a delta-connected tertiary with no connections brought out, the power transformer may be treated as a two winding transformer for protection purposes. It can be protected as presented in Figure 10(c).

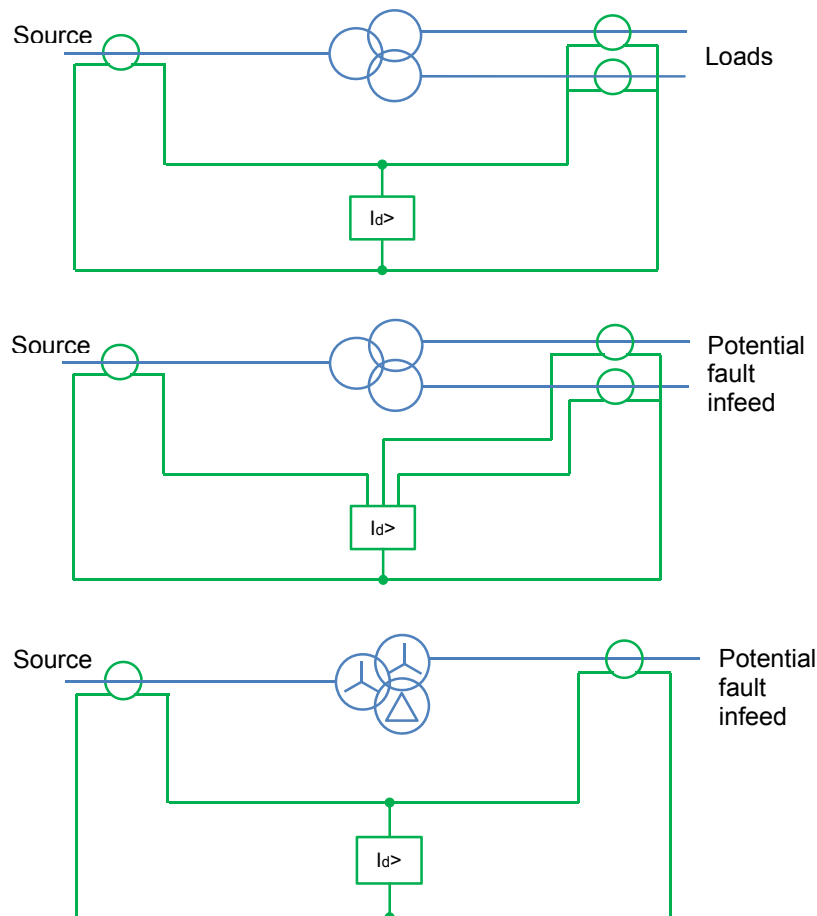

Figure 10. Differential protection schemes for three-winding transformers (single phase shown for simplicity) (a) Three winding transformer (one power source) (b) Three winding transformer (three power sources) (c) Three winding transformer with unloaded delta tertiary

DIFFERENTIAL PROTECTION STABILISATION DURING MAGNETISING INRUSH CONDITIONS

The magnetizing inrush generates current input to the energized winding which does not have equivalent on the other windings. Hence, the total inrush current appears, as unbalance and the differential protection cannot distinguish it from current due to an internal fault. The bias setting is not in effect and an increase in the protection setting to a value that would avoid tripping would make the protection of insignificant value. Therefore methods of delaying, restraining or blocking the differential device must be applied to prevent protection mal-operation.

TIME DELAY

Since the process is transient, stability can be kept by implementing a small time delay. However, the method is no longer used since this time delay also delays functioning of the protection relay in the event of a fault happening at switch-on.

HARMONIC RESTRAINT

Although the inrush current typically resembles an in-zone fault current, it differs a lot once the waveforms are compared. The waveform difference can be applied to distinguish between these conditions. As previously mentioned, the inrush current contains all harmonic orders, but not all of them are equally suited for providing bias. In reality, only the second harmonic is used since it is present in all inrush waveforms. The ratio of second harmonic changes with the degree of saturation of the core, but is always present as long as the uni-directional component of flux exists. The amount changes depending on the transformer design. Normal fault currents do not contain second or other even harmonics. Also, distorted currents flowing in saturated iron cored coils under steady state conditions do not contain second harmonics. Current transformer output current that is energized into steady state saturation will contain odd harmonics but not even harmonics. Nevertheless, should the current transformer be saturated by the transient component of the fault current, the resulting saturation is not symmetrical and even harmonics are introduced into the output current. This can enhance the through fault stability performance of a differential protection relay.

Hence, the second harmonic is an attractive basis for a stabilizing bias against inrush effects. However, care has to be taken to ensure that the current transformers are large enough so that the harmonics generated by transient saturation do not delay protection relay normal operation. The differential current is transferred through a filter that pulls out the second harmonic. This component is then used to generate a restraining quantity sufficient to overcome the operating tendency due to the whole of the inrush current that runs in the operating circuit. Sensitive and high-speed system can be obtained by using this principle.

INRUSH DETECTION BLOCKING – GAP DETECTION TECHNIQUE

Another inrush current characteristic can be seen in Figure 5. The two waveforms (c) and (d) have periods in the cycle where the current is zero. In theory, the minimum duration of this zero period is one quarter of the cycle and is discovered by a simple timer T_1 that is set to $1/4f$ seconds. Figure 11 presents the circuit in block diagram form. Timer T_1 generates an output only if the current is zero for a time exceeding $1/4f$ seconds. It is reset when the differential current instantaneous value surpasses the setting reference.

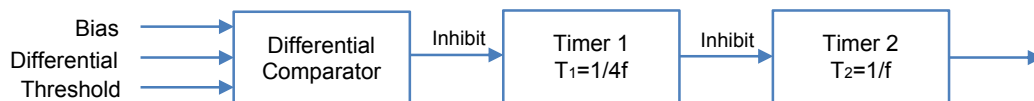

Figure 11. Block diagram used to present waveform gap-detecting principle

As the zero in the inrush current happens towards the end of the cycle, it is mandatory to delay differential relay operation by $1/f$ seconds to ensure that the potential zero condition can be detected. This is accomplished by using a second timer T_2 that is held reset by an output from timer T_1 . When no current is running for a time exceeding $1/4f$ seconds, timer T_2 is held reset and the differential relay that may be controlled by these timers is blocked. When a differential current exceeding the relay setting flows, timer T_1 is reset and timer T_2 times out to give a trip signal in $1/f$ seconds. In the case, differential current is characteristic of transformer inrush then timer T_2 will be reset on each cycle and the trip signal is blocked. Some numerical protection relays may use a combination of the harmonic restraint and gap detection methods for magnetizing inrush detection.

COMBINED DIFFERENTIAL AND RESTRICTED EARTH FAULT SCHEMES

The benefits to be achieved by the restricted earth fault protection application, lead to the system being commonly used in conjunction with an overall differential system. The importance of this is presented in Figure 12. It shows that if the neutral of a star-connected winding is grounded through a resistance of one per unit, an overall differential system having an effective setting of 20% will discover faults in only 42% of the winding from the line end.

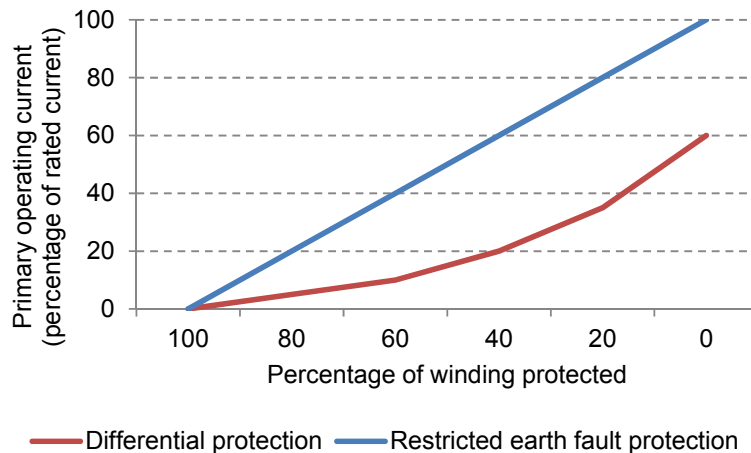

Figure 12. Portion of protected winding when power transformer is resistance grounded and ratings of transformer and resistor are equal

Implementation of a combined differential/REF protection arrangement is simple if a numerical relay with software ratio/phase compensation is used. All compensation is achieved internally in the relay. In the case software ratio/phase correction is not available, either a summation transformer or auxiliary CTs can be applied. The connections are presented in Figure 13 and Figure 14 respectively. The only significant disadvantage of the Combined Differential/REF arrangement is that the REF element is likely to trip for heavy internal faults along with the differential elements, therefore making subsequent fault assessment somewhat confusing. Nevertheless, the saving in CTs outweighs this disadvantage.

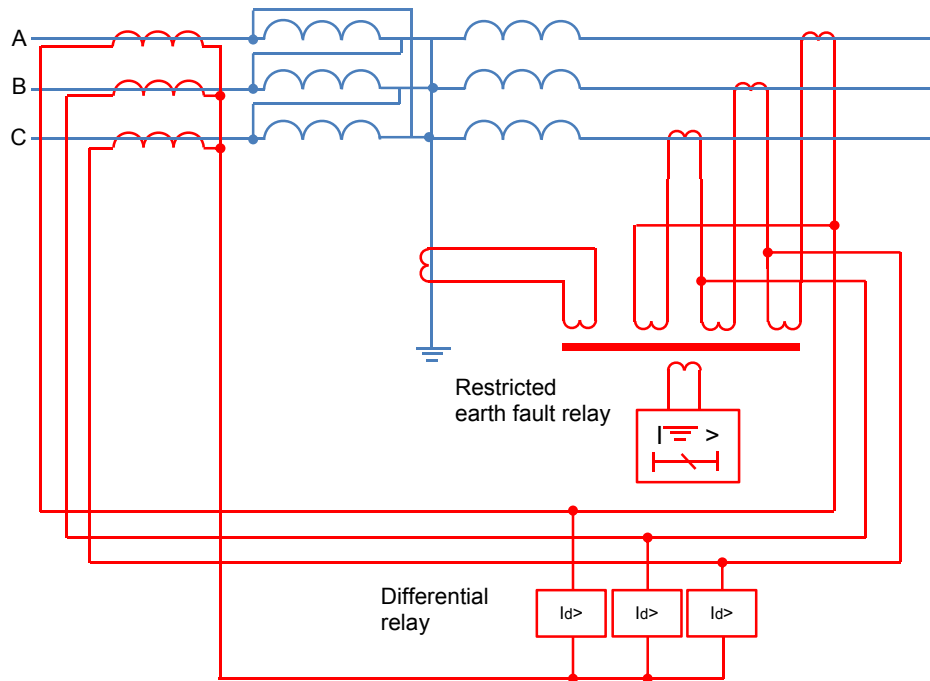

Figure 13. Combined differential and earth fault protection using summation current transformer

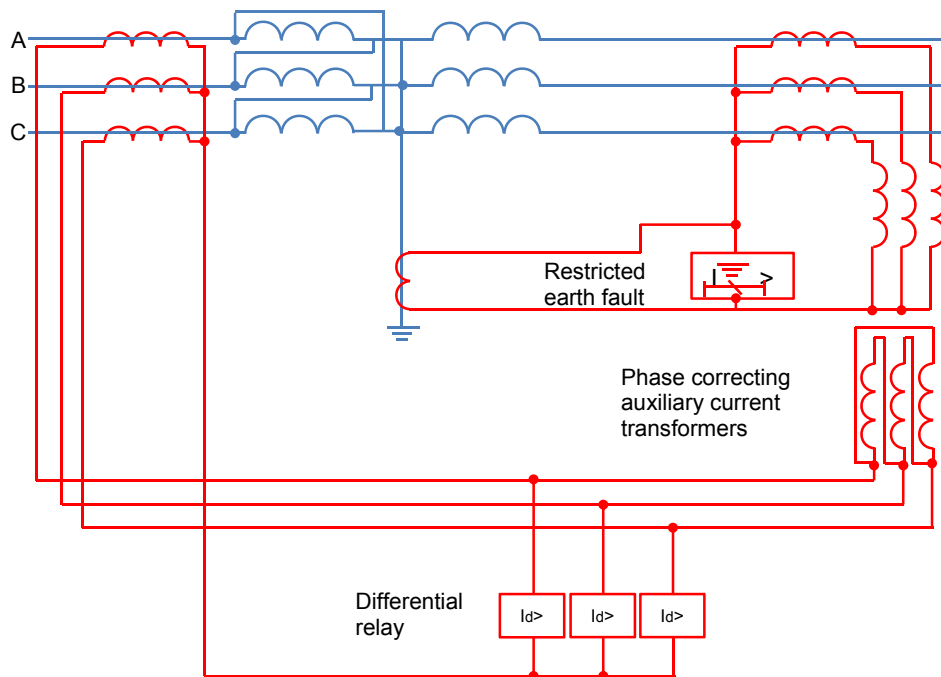

Figure 14. Combined differential and restricted earth-fault protection using auxiliary CTs

APPLICATION WHEN AN EARTHING TRANSFORMER IS CONNECTED WITHIN THE PROTECTED ZONE

A delta-connected winding cannot transfer any zero sequence current to ground fault on the connected system. Any current that does flow is in consequence of the grounded neutral elsewhere on the system and will have a 2-1-1 pattern of current distribution between phases. When the power transformer represents a major power feed, the system may be grounded at that point by an earthing transformer or earthing reactor. They are frequently used in the system, close to the main supply transformer and within the transformer protection zone. Zero sequence current that runs through the earthing transformer during system ground faults will run through the line current transformers on this side, and, without an equivalent current in the balancing current transformers, will cause unwanted tripping of the relays. The problem can be resolved by subtracting the appropriate component of current from the main CT output. The earthing transformer neutral current is utilized for this purpose. Since this represents three times the zero sequence current, ratio correction is needed. This can take the form of interposing CT's of ratio 1/0.333, put to subtract their output from that of the line current transformers in each phase, as presented in Figure 15. The zero sequence component is cancelled, restoring balance to the differential system. Alternatively, numerical protection relays may use software to complete the subtraction, having computed the zero sequence component internally.

A high impedance protection relay device can be connected in the neutral lead between current transformers and differential relays to give restricted earth fault protection to the winding. As an alternative to the above arrangement, the circulating current system can be accomplished via a three-phase group of interposing transformers that are provided with tertiary windings connected in delta. This winding short-circuits the zero sequence component and removes it from the balancing quantities in the relay circuit. Arrangement is shown in Figure 16. Provided restricted earth fault protection is not needed, the arrangement presented in Figure 16 has the benefit of not needing a current transformer. The arrangement can also be connected as presented in Figure 17 in situations when restricted earth fault protection is needed.

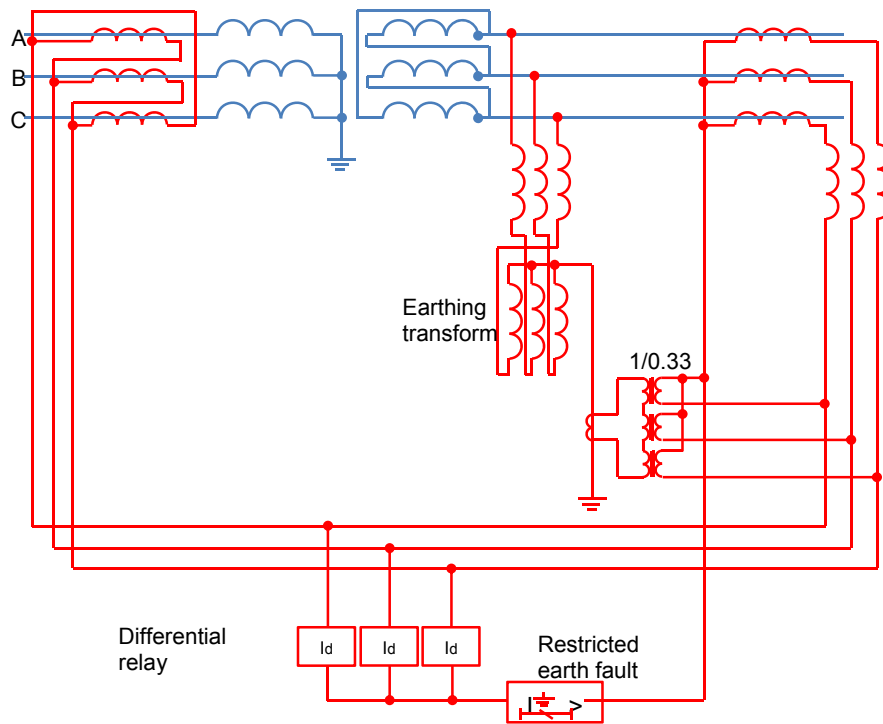

Figure 15. Differential protection with in-zone earthing transformer, with restricted earth fault relay

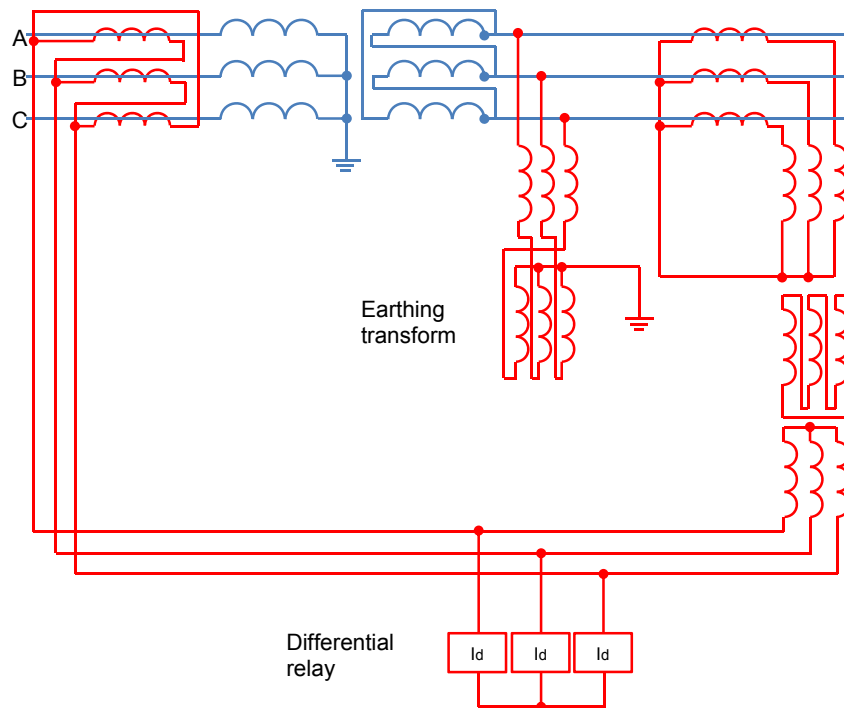

Figure 16. Differential protection with in-zone earthing transformer, no earth fault relay

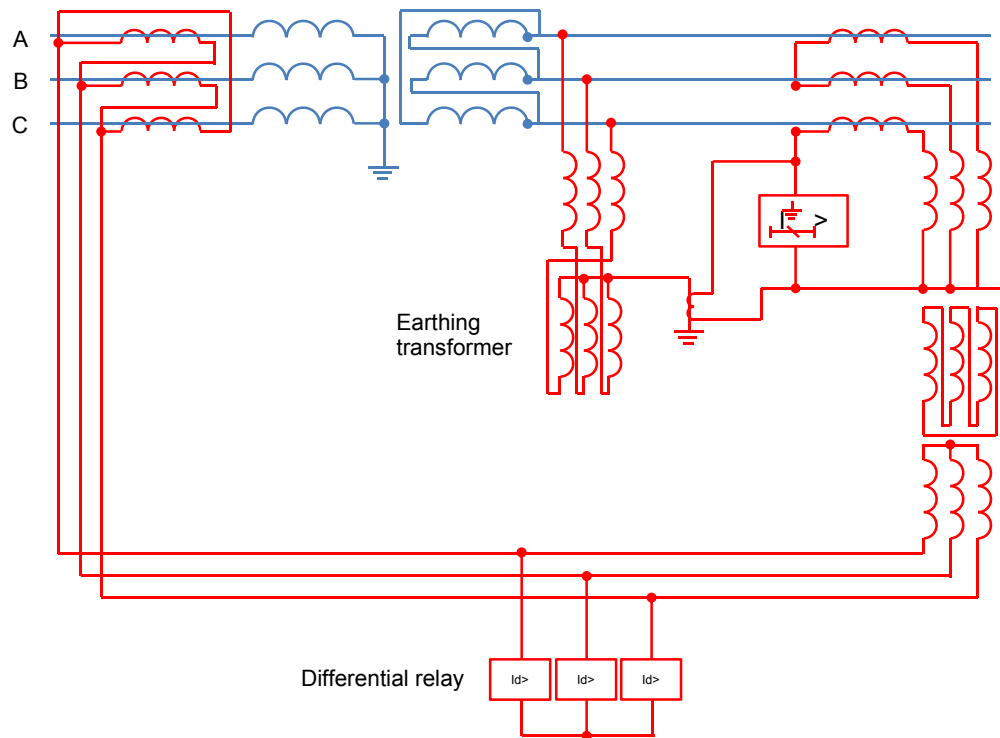

Figure 17. Differential protection with in-zone earthing transformer, with alternative arrangement of restricted earth fault relay

EARTHING TRANSFORMER PROTECTION

Earthing transformers not protected by other methods can use the arrangement presented in Figure 18. The delta-connected current transformers are connected to an overcurrent protection relay having three phase-fault elements. The normal action of the earthing transformer is to transfer zero sequence current. The transformer equivalent current circulates in the delta formed by the CT secondaries without powering the protection relay. It may be set to provide fast and sensitive protection against faults in the earthing transformer itself.

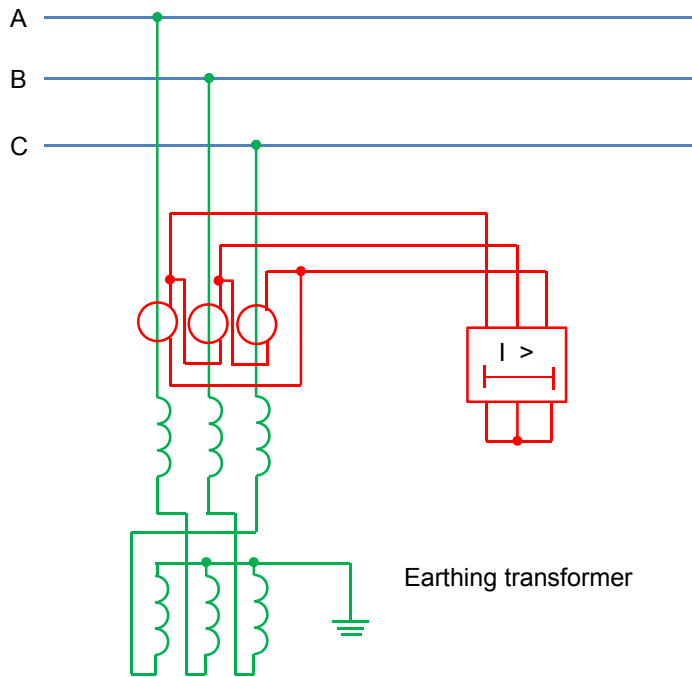
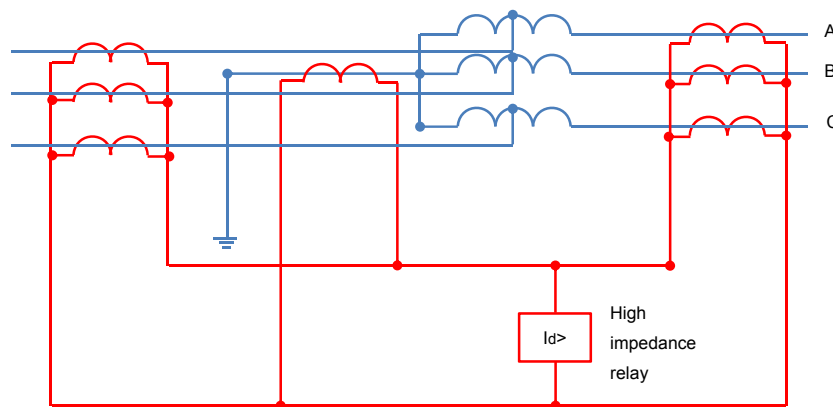

Figure 18. Earthing transformer protection

AUTOTRANSFORMER PROTECTION

Autotransformers are used to connect EHV transmission networks if the ratio of their voltages is small. An option to Differential Protection that can be used for autotransformers is protection based on the principles of Kirchhoff's law to a conducting network. A circulating current system is placed between identical ratio current transformers in the two groups of line connections and the neutral end connections. If one neutral current transformer is installed, this and all the line current transformers can be linked in parallel to a single element protection relay. This protection arrangement, presented in Figure 19, is responsive only to ground faults.



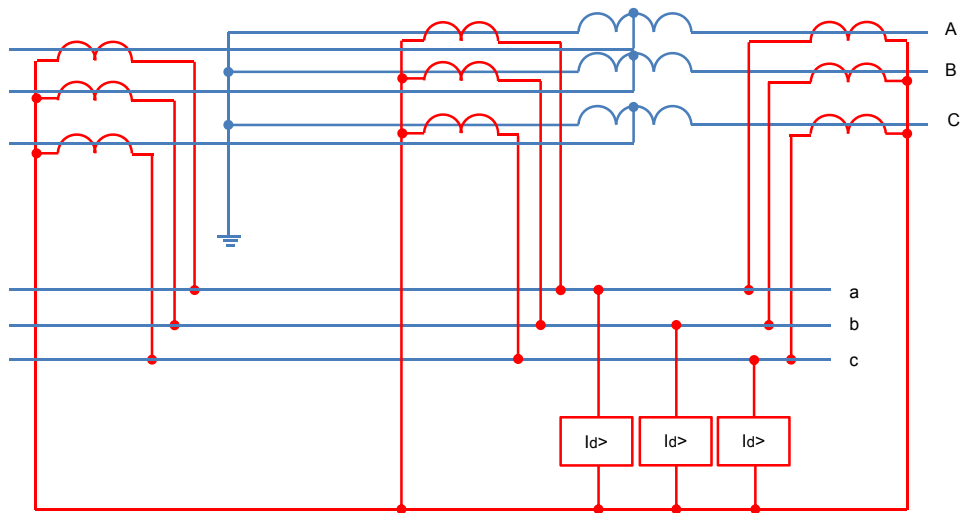

Figure 19. Protection of auto-transformer using high impedance differential relays (a) Ground fault scheme (b) Phase and ground fault scheme

If current transformers are installed in each phase at the neutral end of the windings and a three-element relay is applied, a differential system can be arranged, providing complete protection against phase and ground faults. This arrangement is shown in Figure 19(b). This arrangement ensures high-speed sensitive protection. It is not affected by transformer ratio variations caused by tap-changing. Also this arrangement is resistant to the effects of magnetizing inrush current. Moreover, it does not react to interturn faults. These faults, unless otherwise resolved, will be left to develop into ground faults. Moreover, this arrangement does not react to any fault in a tertiary winding. Unloaded delta-connected tertiary windings are usually not protected. Instead, the delta winding can be grounded at one point through a current transformer that energizes an instantaneous protection relay. This protection arrangement needs to be separated from the main winding protection. If the tertiary winding earthing lead is linked to the main winding neutral above the neutral current transformer in an attempt to make a combined system, there could be 'blind spots' which the protection cannot reach and cover.

TRANSFORMER OVERFLUXING PROTECTION

Transformer overfluxing primarily happens due to following system conditions:

- low system frequency
- high system voltage
- geomagnetic disturbances

Geomagnetic disturbances result in low frequency ground currents circulating through a transmission system. Since momentary system disturbances can cause transient overfluxing that is not critical, time delayed tripping is needed. The normal protection is an IDMT or definite time curve, started if a set V/f threshold is surpassed. Frequently, separate alarm and trip elements are given. The alarm function would be definite time-delayed and the trip function would be an IDMT characteristic. A common characteristic is presented in Figure 20. Geomagnetic disturbances may cause overfluxing without the V/f threshold being surpassed. Some protection relays provide a 5th harmonic detection feature, which can be utilized to discover such situation, as levels of this harmonic increase under overfluxing conditions.

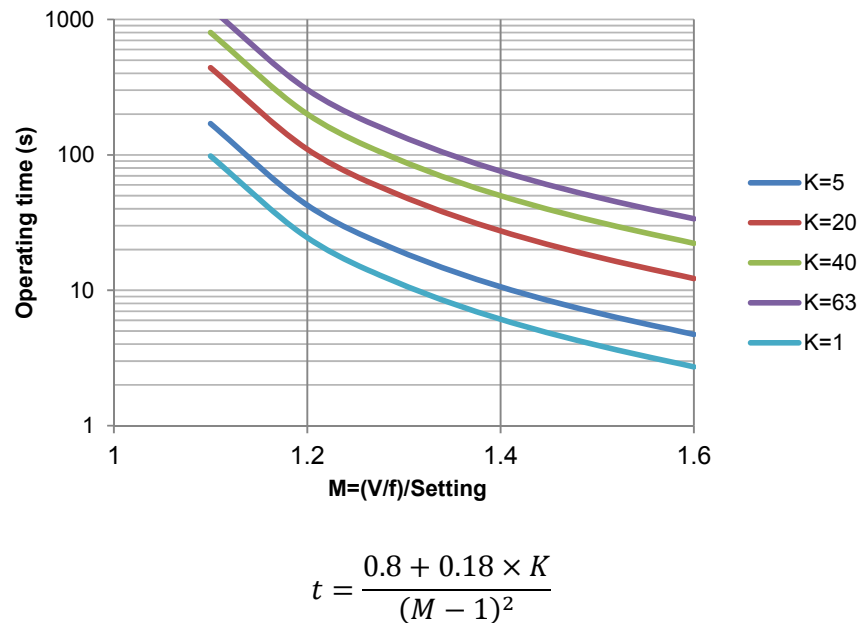

Figure 20. Common IDMT characteristic for overfluxing protection

TRANSFORMER TANK-GROUND PROTECTION

This protection is also known as Howard protection. If the transformer tank is insulated from ground (an insulation resistance of 10 ohms being adequate) ground fault protection can be arranged by connecting a protection relay to the secondary of a current transformer. The primary of the same transformer is connected between the tank and earth.

OIL AND GAS INSTRUMENTS

All faults that happen below oil in an oil-immersed transformer end in localized heating and oil breakdown. Certain degree of arcing will always occur in a winding fault. Resulting oil decomposition will release gases. When the fault is minor, such as a hot joint, gas is slowly released. However, a major fault with severe arcing causes a quick release of large volumes of gas. The process is so powerful that the gas and vapor do not have enough time to escape but instead increase pressure and bodily displace the oil. When such faults happen in transformers with oil conservators, the fault causes a blast of oil to pass up the relief pipe to the conservator. A Buchholz relay is used to protect transformer against such conditions. Devices reacting to abnormally high oil pressure or rate-of-rise of oil pressure are also available and may be applied together with a Buchholz relay.

OIL PRESSURE RELIEF INSTRUMENTS

The simplest pressure relief device is the widely adopted 'frangible disc'. It is usually installed at the end of an oil relief pipe protruding from the transformer tank top. The surge of oil caused by a severe fault bursts the disc, letting the oil to quickly discharge. Relieving and limiting the pressure rise prevents explosive rupture of the tank and subsequent fire risk. Outdoor oil-immersed power transformers are frequently installed in a catchment pit to collect and contain spilt oil, thereby minimizing the possibility of pollution. A drawback of the frangible disc is that the oil remaining in the transformer tank is left exposed to the atmosphere after rupture. This can be avoided using more effective device, the sudden pressure relief valve. This device opens to allow discharge of oil if the pressure exceeds a predetermined level, but closes automatically as soon as the internal pressure drops below preset level. If the abnormal pressure is rather high, the valve can function within a few milliseconds, and provide quick tripping when suitable contacts are fitted. The device is usually installed in power transformers rated at 2MVA or higher. Also it can be used for distribution transformers rated as low as 200kVA, especially those placed in hazardous locations.

SUDDEN PRESSURE RISE RELAY

This relay observes pressure rise rather than absolute pressure and thereby can react even faster than the pressure relief valve to sudden abnormally high pressures.

Precision as low as 0.07bar/s is achievable, but when installed in forced-cooled transformers the operating speed of the device may have to be deliberately slowed to avoid spurious tripping during circulation pump starts. Optionally, fast pressure rise relays may have their output monitored by instantaneous high-set overcurrent elements.

BUCHHOLZ PROTECTION

Buchholz protection is typically installed on all power transformers equipped with a conservator. The Buchholz relay is placed in a cast housing which is connected in the pipe to the conservator, as presented in Figure 21.

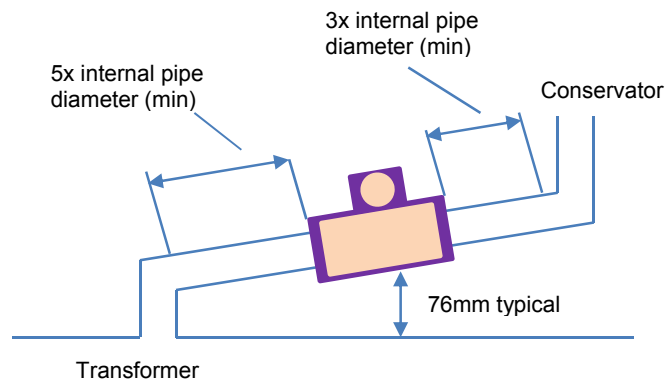

Figure 21. Buchholz relay mounting scheme

A standard Buchholz relay has two sets of contacts. One is used to operate for slow accumulations of gas, the other for huge oil displacement in the case of a heavy internal fault. An alarm is generated for the first set of contacts. The second set of contacts is typically direct-wired to the CB trip relay. Therefore, the device will give an alarm for the following fault conditions:

- hot spots on the core due to short circuit of lamination insulation
- faulty joints
- core bolt insulation failure
- loss of oil due to leakage
- interturn faults or other winding faults involving only lower power infeeds

When a major winding fault happens, this causes a surge of oil, which moves the lower float and therefore causes transformer isolation. This action will happen for:

- all serious winding faults, either to ground or interphase
- loss of oil if allowed to continue to a dangerous degree

An inspection window is typically mounted on both sides of the gas collection space. Visible white or yellow gas shows that insulation has been damaged, while black or grey gas suggests the presence of, dissociated oil. In these situations the gas will likely be inflammable, while released air will not. A vent valve is installed on the top of the housing for the gas to be released or collected for assessment. Power transformers with forced oil circulation may face oil flow to/from the conservator on starting/stopping of the pumps. The Buchholz relay must not function in these situations. Cleaning procedures may cause oil aeration. During these situations, transformer tripping due to Buchholz operation should be inhibited for an adequate period.

Because of its universal response to faults within the power transformer, some of which are hard to discover by other means, the Buchholz relay is invaluable, whether regarded as a main protection or as an addition to other protection arrangements. Tests completed by striking a high voltage arc in a transformer tank filled with oil, have indicated that tripping times of 0.05-0.1s are achievable. Electrical protection is typically also used, either to achieve faster operation for major faults, or because Buchholz relays have to be stopped from tripping during oil maintenance intervals.

TRANSFORMER-FEEDER PROTECTION

A transformer-feeder represents the situation when transformer is directly connected to a transmission circuit without the installation of switchgear. Examples are presented in Figure 22.

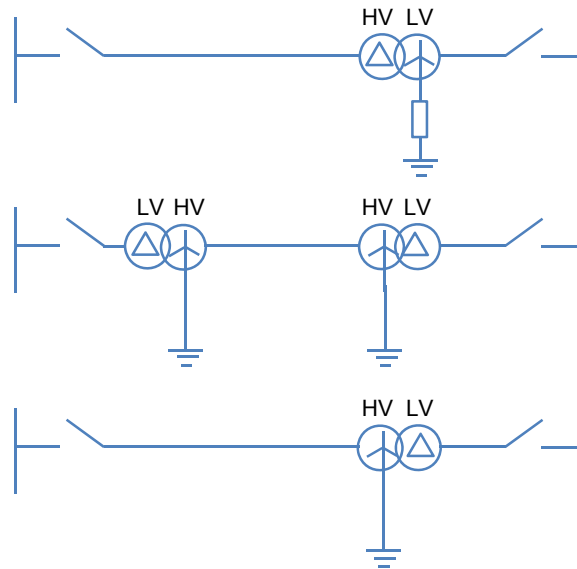

Figure 22. Common transformer-feeder circuits

Accomplished saving in switchgear is offset by additional complexity in the required protection. The primary demand is intertripping, since the feeder remote protection will not react to the low current fault conditions. These conditions can be discovered by restricted earth fault and Buchholz protections. Either unrestricted or restricted protection can be used. Next, the transformer-feeder can be protected as a single zone or used with separate protections for the feeder and the transformer. In the second case, the separate protections can both be unit type systems. An adequate option is the combination of transformer unit protection with an unrestricted system of feeder protection, including an intertripping feature.

NON-UNIT ARRANGEMENTS

The next sections present how non-unit arrangements are used to protect power transformer-feeders against various fault types.

TRANSFORMER FEEDER PHASE AND GROUND FAULTS

High-speed protection against phase and ground faults can be accomplished by distance protection relays installed at the end of the feeder. The transformer represents considerable lumped impedance. Hence, it is possible to set a distance relay zone to protect the whole feeder and reach part way into the transformer impedance. Even though the distance zone is represented as being set 'half way into the transformer', it must not be considered that half the transformer winding will be

protected. The implications of autotransformer actions and changes in the resulting winding impedance prevent this. Protected part of the winding beyond the terminals is very small. The protection is practically limited to the feeder, which gets high-speed protection.

FEEDER PHASE FAULTS

A distance protection is not impacted by varying fault levels on the high voltage busbars. Hence, it is the best arrangement in the case fault level may vary. In situations where the fault level is rather constant, similar protection can be achieved using high set instantaneous overcurrent protection relays. These relays should have a low transient overreach (t), expressed as:

$$\frac{I_S - I_F}{I_F} \times 100\%$$

Where:

I_S – setting current

I_F – steady state r.m.s value of the fault current, which when completely offset, just triggers the protection relay. The instantaneous overcurrent protection relays must be set without risk of them tripping for faults on the transformer remote side. Referring to Figure 23, the required setting to ensure that the protection relay will not trip for a fully offset fault I_{F2} is expressed as:

$$I_S = 1.2(1 + t)I_{F2}$$

where I_{F2} is the fault current under maximum source conditions, which happens when Z_S is minimum. The factor of 1.2 takes into account potential errors in the system impedance and relay and CT errors. Since it is preferable for the instantaneous overcurrent protection to clear all phase faults anywhere within the feeder under varying system operating conditions, it is mandatory to have a protection relay setting less than I_{F1} to ensure fast and reliable operation. Let us define setting ratio resulting from setting I_S as:

$$r = \frac{I_S}{I_{F1}}$$

Hence,

$$rI_{F1} = 1.2(1 + t)I_{F2}$$

Therefore,

$$\begin{aligned} r &= 1.2(1 + t) \frac{Z_S + Z_L}{Z_S + Z_L + Z_T} \\ &= 1.2(1 + t) \frac{Z_S + Z_L}{(1 + x)(Z_S + Z_L)} \\ &= \frac{1.2(1 + t)}{1 + x} \end{aligned}$$

Where:

$$x = \frac{Z_T}{Z_S + Z_L}$$

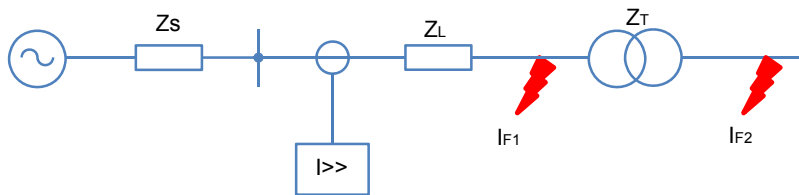

Transient over-reach (%)	Setting ratio $r = \frac{I_S}{I_{E1}}$			
	5	25	50	100
0.25	1.01	1.20	1.44	1.92
0.5	0.84	1.00	1.20	1.60
1.0	0.63	0.75	0.90	1.20
2.0	0.42	0.50	0.60	0.80
4.0	0.25	0.30	0.36	0.48
8.0	0.14	0.17	0.20	0.27

Figure 23. Transformer-feeder protection over-reach considerations

It can be noted that for a specified transformer size, the most sensitive protection for the feeder will be accomplished by using protection relays with the lowest transient overreach. It should be mentioned that where r is higher than 1, the protection will not cover the whole feeder. Also, any growth in source impedance above the minimum value will increase the effective setting ratios above those that are presented. The instantaneous protection is typically used with a time delayed overcurrent device having a lower current setting. In this way, instantaneous protection is supplied for the feeder, with the time-delayed device covering faults on the power transformer. When the power can flow in the transformer-feeder in both directions, overcurrent protection relays will be needed at both ends. In the case of parallel transformer-feeders, it is

crucial that the overcurrent protection relays on the low voltage side are directional, tripping only for fault current fed into the transformer-feeder.

GROUND FAULTS

Instantaneous restricted earth fault protection is typically used. When the high voltage winding is delta connected, a protection relay in the residual circuit of the line current transformers provides ground fault protection. Essentially it is limited to the feeder and the related delta-connected transformer winding. The delta-connected transformer winding cannot transfer any zero sequence current to a through earth fault. When the feeder is associated with grounded star-connected winding, normal restricted earth fault protection cannot be used because of the remoteness of the transformer neutral. Restricted protection can be used using a directional earth fault protection relay. A simple sensitive and high-speed directional device can be applied, but care has to be taken for the element transient stability. Optionally, a directional IDMT protection relay can be applied but the time multiplier has to be set low. The slight inverse time delay in operation will ensure that unwanted transient operation is avoided. When the supply source is on the high voltage star side, an optional arrangement that does not need a voltage transformer can be applied. The arrangement is presented in Figure 24. For the circuit breaker to trip, both protection relays A and B must function. That will happen for ground faults on the feeder or transformer winding.

External ground faults cause the power transformer to deliver only zero sequence current. It will circulate in the closed delta connection of the secondary windings of the three auxiliary current transformers. Output is not available to protection relay B. Through phase faults will trigger relay B, but not the residual relay A. Relay B must have a setting above the maximum load. Since the grounding of the neutral at a receiving point is likely to be solid, the ground fault current will be comparable with the phase fault current. Therefore, high settings are not a serious limitation.

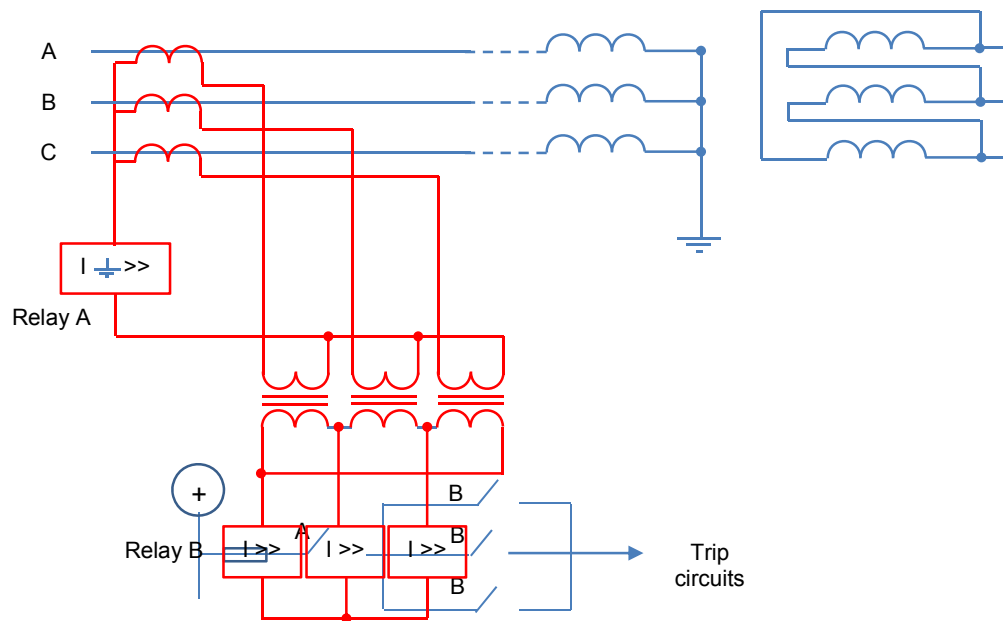

Figure 24. Instantaneous protection of transformer-feeder

Ground fault protection of the low voltage winding will be accomplished by a restricted ground fault system using either three or four current transformers, depending on winding connection.

IN-ZONE CAPACITANCE

The feeder part of the transformer-feeder connection will have considerable capacitance between each conductor and ground. During an external ground fault the neutral will be shifted and the resulting zero sequence voltage component will generate a corresponding zero sequence capacitance current component. In the case of complete neutral displacement, zero sequence current will be equal in value to the normal positive sequence current. The resulting residual current is equal to three times the zero sequence current and therefore to three times the normal line charging current. The value of in-zone current component should be looked at when establishing the effective setting of earth fault protection relays.

UNIT ARRANGEMENTS

The major differences between the demands of feeder and transformer protections lie in the limitation imposed on the transfer of ground fault current by the transformer and the need for transformer high sensitivity protection. This implies that the two components of a transformer-feeder connection should be separately protected. This

means installation of current transformers adjacent to, or on, the transformer high voltage terminals. Separate current transformers are needed for the feeder and transformer protections so that these can be organized in two separate overlapping zones. The application of common current transformers is possible, but may involve the application of auxiliary current transformers, or relay special winding and connection arrangements. Intertripping of the remote circuit breaker from the transformer protection will be required, but this can be accomplished using the communication facilities of the feeder protection relays. Even though technically dominant, the application of different protection systems is rarely justifiable in comparison with an overall system or a combination of non-unit feeder protection and a unit transformer system. An overall unit system must consider the fact that zero sequence current on one side of a transformer may not be reproduced in any form on the other side. This introduces little trouble to a modern numerical relay using software phase/zero sequence compensation and digital communications to transmit complete information on the phase and ground currents from one relay to the other. Nevertheless, it does create a more challenging problem for protection relays using older technology. The line current transformers can be connected to a summation transformer with unequal taps, as presented in Figure 25(a). This scheme generates an output for phase faults and also some response for A and B phase-ground faults. Nevertheless, the resulting settings will be similar to those for phase faults and no protection will be given for C phase earth faults. An optional arrangement is presented in Figure 25(b). The B phase is taken through a separate winding on another transformer or protection relay electromagnet, to create another balancing system. The two power transformers are connected with their counterparts at the other end of the feeder-transformer by four pilot wires. Service with three pilot cores is possible but four are preferred, requiring insignificant increase in pilot cost.

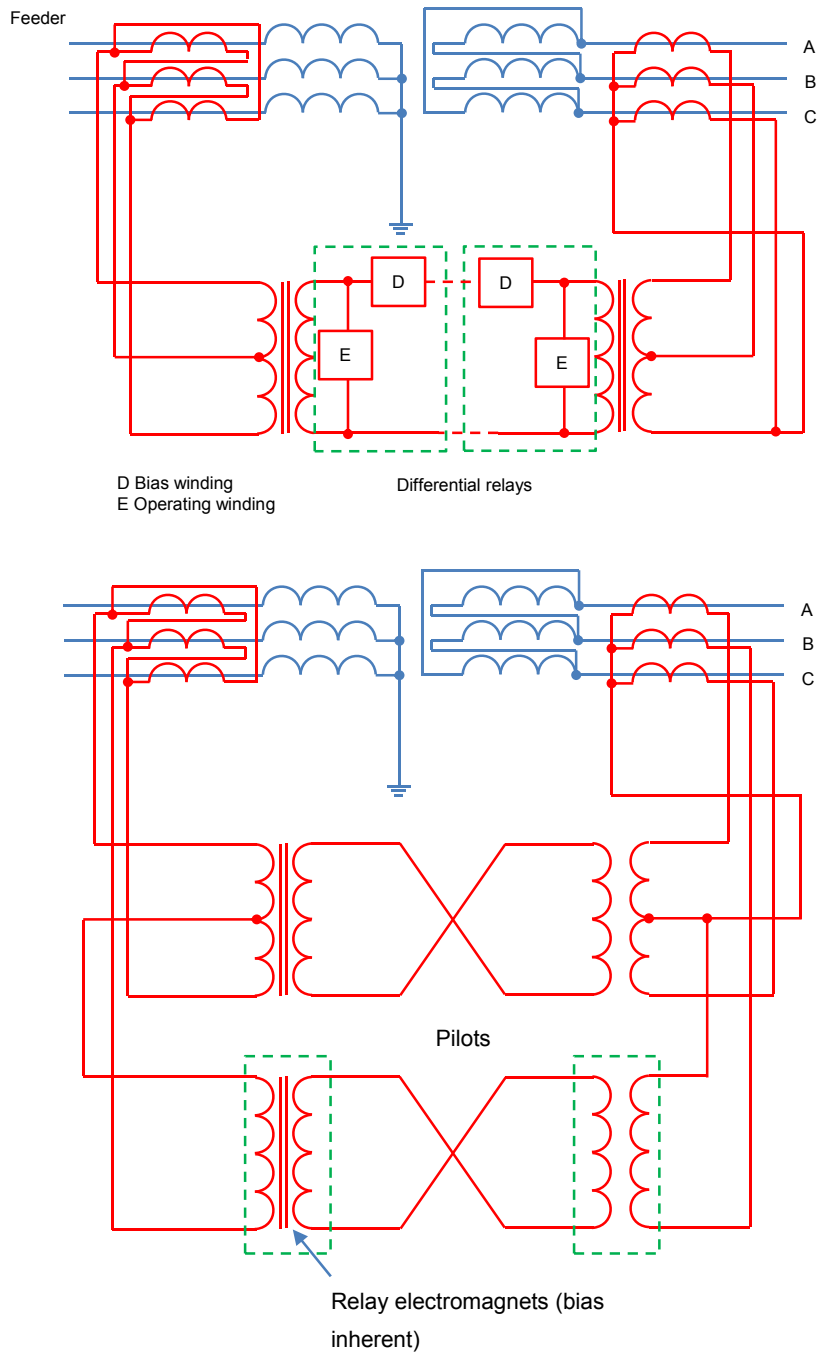

Figure 25. Protection methods for transformer-feeders using electromechanical static technology (a) Circulating current system (b) Balanced voltage system

INTERTRIPPING

To make sure that both the high and low voltage circuit breakers trip for faults within the transformer and feeder, it is mandatory to operate both circuit breakers from protection typically associated with one. The technique for accomplishing this is known as intertripping. The requirement for intertripping on transformer-feeders is based on

the fact that certain fault types generate insufficient current to operate the protection associated with one of the circuit breakers. These faults are:

- Transformer faults that operate the Buchholz relay and trip the local low voltage circuit breaker. However, these faults fail to generate sufficient fault current to operate the protection related with the remote high voltage circuit breaker
- Ground faults on the transformer star winding, which, because of the position of the fault in the winding, again cannot generate sufficient current for relay operation at the remote circuit breaker
- Ground faults on the feeder or high voltage delta connected winding which only trip the high voltage circuit breaker. However, the transformer is left energized from the low voltage side and with two high voltage phases at near line-to-line voltage above ground. Intermittent arcing may happen and there is a chance of transient overvoltage happening and causing a further insulation breakdown.

NEUTRAL DISPLACEMENT

An alternative to intertripping is to find the condition by measuring the residual voltage on the feeder. Ground fault happening on the feeder connected to an unearthed transformer winding should be cleared by the feeder circuit. In the case there is a source of supply on the transformer secondary side, the feeder may be still energized. The feeder will then be a local unearthed system, and, if the ground fault continues in an arcing condition, severe overvoltages may happen. A voltage protection relay is energized from the broken-delta connected secondary winding of a voltage transformer on the high voltage line. It gets an input proportional to the zero sequence voltage of the line. Arrangement is shown in Figure 26. The protection relay typically receives zero voltage, but, in the case of ground fault, the broken-delta voltage will rise to three times the phase voltage. Ground faults elsewhere in the system may also result in displacement of the neutral. Therefore, discrimination is accomplished using definite or inverse time characteristics.

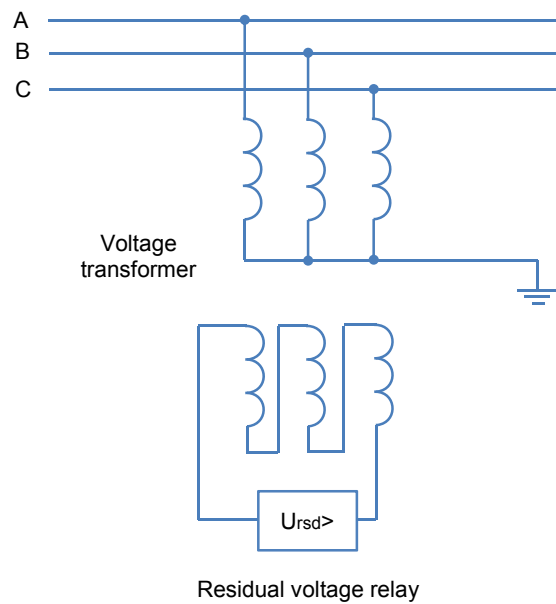

Figure 26. Neutral displacement detection using voltage transformer

TRANSFORMER CONDITION MONITORING

It is practical to equip power transformers with measuring instruments to discover early degradation signs of different components and give warning to the operator. This way lengthy and expensive outage due to failure can be avoided. This strategy, which can be used to other devices as well as transformers, is known as condition monitoring. It is implemented with the goal to provide the operator with regular information on the transformer condition. By reviewing the provided information trends, the operator can make an educated judgment regarding maintenance frequency and detect early deterioration signs. If ignored, these signs would lead to internal faults. Monitoring techniques are an addition to, but are not a replacement for transformer protection. The extent to which transformer condition monitoring is used depends on many factors, amongst which are asset owner policy, the suitability of the design, the importance of the asset to system service, and the general reliability record. Hence, it should not be expected that all transformers are equipped with condition monitoring instruments. A common condition monitoring system for an oil-immersed power transformer is capable of monitoring the condition of different transformer components. This is summarized in Table 4. There can be certain overlap with the measurements available from a digital/numerical protection relay. The operator can be presented with transformer health information or raised alarms by using the software to store and complete trend analysis of the measured data. This will typically give the operator early

warning of degradation thus allowing maintenance to correct the problem before failure happens. Apparently, the maintenance can be organized to meet system running conditions, given the rate of degradation is not excessive.

As asset owners become more aware of the unplanned outage costs the usefulness of condition monitoring will continue to grow.

Monitored Equipment	Recorded Quantity	Status Information
Tank	Oil temperature	Hot-spot temperature
		Permissible overload rating
	Gas in oil content	Oil quality
		Winding insulation condition
	Moisture in oil content	Oil quality
	Buchholz gas content	Winding insulation condition
Tap changer	Position	Frequency of use of each tap position
	Drive power consumption	OLTC health
	Total switched load current	OLTC contact wear
	OLTC oil temperature	OLTC health
Coolers	Oil temperature difference	Cooler efficiency
	Cooling air temperature	
	Ambient temperature	
	Pump status	Cooling plant health
Conservator	Oil level	Tank integrity
Bushings	Voltage	Insulation quality
	Partial discharge measurement (wideband voltage)	
	Load current	Loading
		Permissible overload rating
		Hot-spot temperature
	Oil pressure	Insulation quality

Table 4. Typical transformer condition monitoring

TRANSFORMER PROTECTION EXAMPLES

Next sections give examples of the modern relays used for transformer protection. Alstom type KBCH protection relay is used to present the complexity of the required calculations.

PROVISION OF VECTOR GROUP COMPENSATION AND ZERO-SEQUENCE FILTERING

Figure 27 presents a delta-star transformer that needs to be protected by using a unit protection arrangement. Considering a Dyn11 main winding connection, appropriate selection of primary and secondary CT winding arrangements and software phase compensation needs to be made. With the KBCH protection relay, phase compensation is chosen by the user in the form of software implemented ICTs.

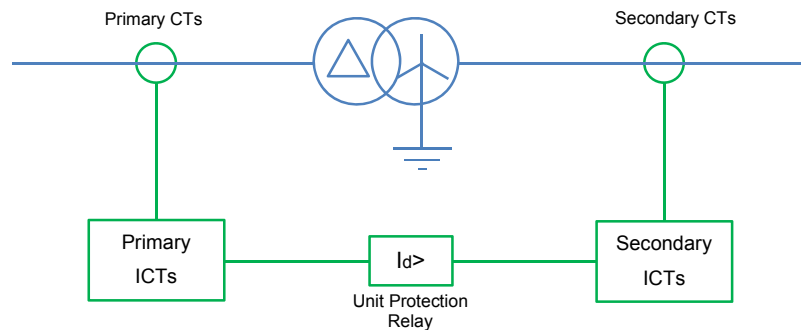

Figure 27. Example of transformer zero-sequence filtering

Considering the Dyn11 connection, the secondary voltages and currents are displaced by $+30^\circ$ from the primary. Hence, the combination of primary, secondary and phase correction must provide a phase shift of -30° so that secondary quantities remain relative to the primary. For simplicity, the CTs on the primary and secondary transformer windings are star connected. The needed phase shift can be accomplished either by use of ICT connections on the primary side having a phase shift of $+30^\circ$ or on the secondary side having a phase shift of -30° . There is a wide combination of primary and secondary ICT winding connections that can provide this, such as Yd10 ($+60^\circ$) on the primary and Yd3 (-90°) on the secondary. Second possibility is Yd11 ($+30^\circ$) on the primary and Yy0 (0°) on the secondary. It is typical to select the simplest possible arrangements, and hence the second of the above two possibilities could be selected. Nevertheless, the current distribution in the transformer primary and secondary windings caused by an external earth fault on the transformer secondary side must be considered. The transformer has an earth connection on the secondary winding, so it can transfer zero sequence current to the fault. Application of star connected main CTs and Yy0 connected ICTs gives a path for the zero sequence

current that can reach the protection relay. On the transformer primary side, the delta connected main primary winding causes zero-sequence current to circulate round the delta. Therefore they will not be detected by the primary side main CTs. Hence, the protection relay will not detect any zero-sequence current on the transformer primary side. Instead it detects the secondary side zero sequence current incorrectly as an in-zone fault. The solution is to install the ICTs on the transformer secondary side with a delta winding. That way the zero-sequence current would circulate round the delta and would not be detected by the relay. Hence, a general rule can be adopted. It states that the transformer winding with a connection to earth must have a delta-connected main or ICT for unit protection to function correctly. Yy0 connection selection for the primary side ICTs and Yd1 (-30°) for the secondary side ICTs gives the required phase shift and the zero-sequence trap on the secondary side. Modern numerical protection relays use a setting wizard that requires entering only vector group and zero sequence data. The protection relay then automatically adjusts itself to suit the application.

DELTA-STAR TRANSFORMER UNIT PROTECTION

Figure 28 presents a delta-star transformer to which unit protection needs to be applied. Restricted earth fault protection to the star winding also needs to be used. Referring to the figure, the ICTs have already been correctly chosen, and are conveniently set in software. Hence, it remains to compute adequate compensation ratio (it is assumed that the transformer does not have taps), transformer differential protection settings and restricted earth fault settings.

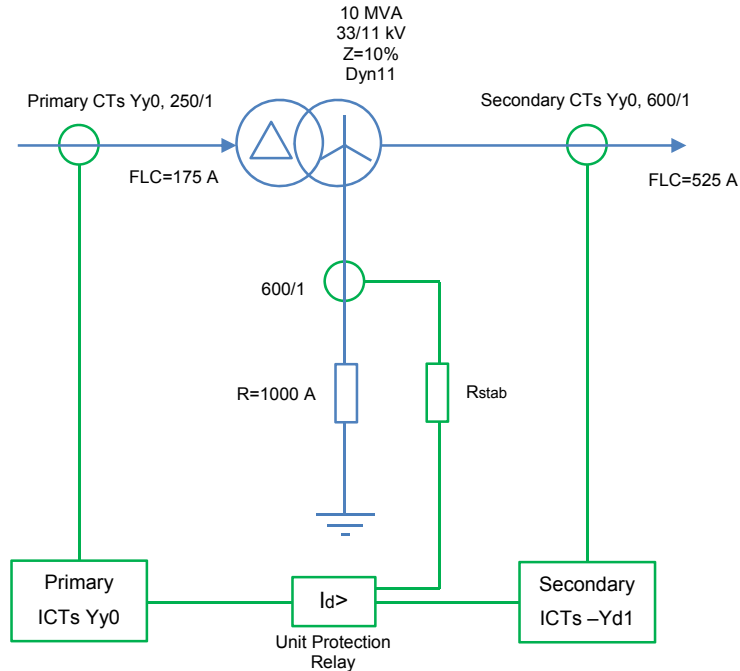

Figure 28. Example of transformer unit protection

RATIO COMPENSATION

Power transformer HV full load current on secondary of main CTs is:

$$\frac{175}{250} = 0.7$$

$$\text{Ratio compensation} = \frac{1}{0.7} = 1.428$$

Select nearest value = 1.43

$$\text{LV secondary current} = \frac{525}{600} = 0.875$$

$$\text{Ratio compensation} = \frac{1}{0.875} = 1.14$$

TRANSFORMER UNIT PROTECTION SETTINGS

A current setting of 20% of the nominal relay current is suggested. This corresponds to 35A primary current. The KBCH protection relay has a dual slope bias characteristic with fixed bias slope settings of 20% up to rated current and 80% above that level. The corresponding characteristic is presented in Figure 29.

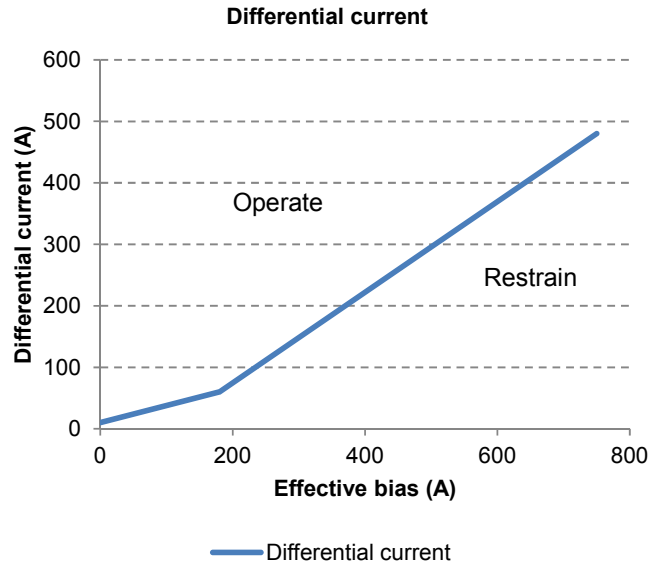

Figure 29. Power transformer unit protection characteristic

RESTRICTED EARTH FAULT PROTECTION

The KBCH protection relay uses high-impedance Restricted Earth Fault (REF) protection. Operation is needed for a primary earth fault current of 25% rated ground fault current (i.e. 250A). The main task in calculating settings is to determine the value of the stabilizing resistor R_{stab} and stability factor K . A stabilizing resistor is needed to ensure through fault stability when one of the secondary CTs saturates while the others do not. The requirements can be presented as:

$$V_S = I_S R_{stab}$$

And

$$V_S > K I_f (R_{CT} + 2R_l)$$

Where:

- V_S – stability voltage setting
- V_K – CT knee point voltage
- K – protection relay stability factor
- I_S – protection relay current setting
- R_{CT} – CT winding resistance
- R_l – CT lead resistance
- R_{stab} – stabilizing resistor

For this example:

$$V_K = 97 \text{ V}$$

$$R_{CT} = 3.7 \ \Omega$$

$$R_l = 0.057 \ \Omega$$

For the used protection relay, the different factors are related as shown in the Figure 30.

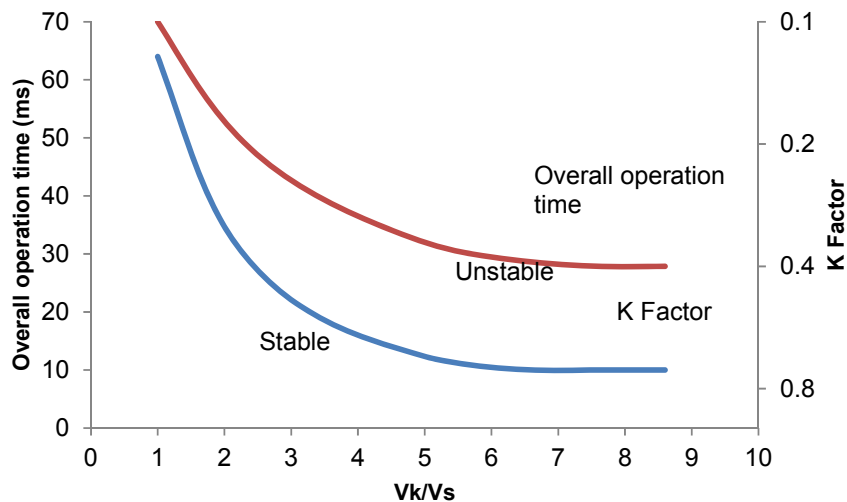

Figure 30. REF operating characteristic for KBCH protection relay

Starting with the desired operating time, the V_K/V_S ratio and K factor can be determined. An operating time of 40ms (2 cycles at 50Hz) is typically acceptable. Therefore, from Figure 30 it can be determined:

$$\frac{V_K}{V_S} = 4, K = 5$$

The maximum ground fault current is limited by the grounding resistor to 1000A (primary). The maximum phase fault current can be guessed by assuming the source impedance is zero. In that case it is limited only by transformer impedance to 5250A, or 10A secondary after taking account of the ratio compensation. Therefore, the stability voltage can be computed as:

$$V_S = 0.5 \times 10(3.7 + 2 \times 0.057) = 19.07 \text{ V}$$

Therefore,

$$\text{Calculated } V_K = 4 \times 19.07 = 76.28 \text{ V}$$

However,

Actual $V_K = 91V$ and $V_K/V_S = 4.77$

Therefore, with $K = 0.5$, the protection is unstable as can be seen in Figure 30.

By applying an iterative process for V_K/V_S and K , a final acceptable result of $V_K/V_S = 4.55$, $K=0.6$ is reached. This results in a tripping time faster than 40ms.

The needed ground fault setting current I_{OP} is 250A. The selected E/F CT has an exciting current I_e of 1%. Therefore, using the formula:

$$I_{OP} = CT_{ratio} \times (I_S + nI_e)$$

where:

n = no of CTs in parallel (=4)

$I_S = 0.377$, use 0.38 nearest settable value.

The stabilizing resistance R_{stab} can be calculated as 60.21Ω.

The protection relay can only withstand a maximum of 3kV peak under fault conditions. A check is needed to understand if this voltage is surpassed – if it is, a non-linear resistor, must be connected across the protection relay and stabilizing resistor. The peak voltage is calculated using the equation:

$$V_P = 2\sqrt{2V_K(V_f - V_K)}$$

Where:

$$V_f = I_f(R_{CT} + 2R_l + R_{stab})$$

And

I_f = fault current in secondary of CT circuit. Substituting values gives $V_P = 544 V$. Thus a non-linear resistor is not needed.

ON-LOAD TAP CHANGING TRANSFORMER UNIT PROTECTION

The previous example considers a transformer without the taps. In reality, majority of transformers have a range of taps to cater for different loading situations. While majority of transformers have an off-load tap-changer, power transformers used for network voltage control are equipped with an on-load tap-changer. The protection settings must consider tap-change variation to avoid the chance of spurious trips at extreme tap positions. For this example, the same transformer as in previous section will be used, but with an on-load tapping range of +5% to -15%. The tap-changer is installed on the primary winding, while the tap-step typically does not matter.

RATIO CORRECTION

The mid-tap position is used to compute the ratio correction factors. The mid tap position is -5%. At this tap position:

Primary voltage to give rated secondary voltage: = $33 \times 0.95 = 31.35kV$

Rated Primary Current = $184A$

Transformer HV full load current on secondary of main CTs is:

$$\frac{184}{250} = 0.737$$

$$\text{Ratio compensation} = \frac{1}{0.737} = 1.36$$

$$\text{LV secondary current} = \frac{525}{600} = 0.875$$

$$\text{Ratio compensation} = \frac{1}{0.875} = 1.14$$

Both of the above values can be set in the protection relay.

BIAS SLOPE SETTING

The on-load tapping range of +5% to -15% provides rise to a maximum excursion of -10% from the -5% mid-tap position. Since the differential protection scheme notionally balances at this mid-tap, it means that approximately, the maximum differential current that can flow when at top or bottom tap is 10% of the load (or fault current which may

flow to an external fault). Protection relays having an adjustable k1 bias slope setting should ensure that it is at least 10% higher than the percentage excursion.

POWER TRANSFORMER ASSET MANAGEMENT

Due to the transformer high capital cost and the high requirement for their in-service availability, protection is no-longer the only issue. As cities expand, consumers' lifestyle demands increase and electric vehicle recharging loads become more prevalent, overall power demand increases. This puts a focus on knowing the transformer health in real-time. Maintenance at a selected time is far more preferred than a forced unplanned outage caused by the failure. Next paragraphs provide an overview of techniques that are usually available in modern numerical transformer protection relays and that can be used for asset management of the protected transformer.

LOSS OF LIFE MONITORING

Transformer insulation ageing is a time-dependent function of temperature, moisture, and oxygen content. The moisture and oxygen impact to insulation degradation are minimized due to the preservation systems used in the modern transformer design. Hence, temperature is the vital parameter in insulation ageing. Frequent overloads will shorten the transformer life-expectancy due to the elevated winding temperatures. Insulation deterioration is not uniform, and will be severer at transformer tank hot-spots. Hence, any asset management system used to predict the deterioration rate must do so based on simulated real-time hot spot temperature algorithms. These calculations have to consider ambient temperature, top-oil temperature, load current, the status of oil pumps (pumping or not) and the status of radiator fans (forced cooling or not). Thermal model is defined in IEEE Standard C57.91 and can be used for loss of life monitoring. The protection algorithm calculates the current rate of losing life, and uses that to suggest the remaining years or hours until critical insulation health statuses are reached. Such criticalities will usually relate to known percentage degradations in the insulation tensile strength, degradation in the degree of polymerization, and other life-loss factors. The asset owner can be alarmed in advance that an outage will be needed for reconditioning or rewinding. That way investment budgeting can be made years and months ahead of time.

TRANSFORMER THROUGH-FAULT MONITORING

Loss of life monitoring is used to track the deterioration caused by long term, repeated overloading. Nevertheless, it is not the right method to monitor short-term heavy fault currents which flow through the transformer. Through faults are a major cause of transformer failure and damage, as they stress the insulation and mechanical integrity. A special through-fault monitor is needed to monitor currents introduced by external faults that pass through the transformer. These currents may range from 3.5 times up to tens of times of the transformer rated current. Many relays perform an I^2t calculation when the through current exceeds a user-set threshold. That way the heating effect of the square of the maximum phase current, and the fault duration are calculated. Calculation results are added to monitored cumulative values so that utilities can organize transformer maintenance or specify required system reinforcement.